

# Vibrating Wire Displacement Transducers

### Applications

The 4400 Series are designed to measure or monitor the...

- Expansion or contraction of a joint
- Strains in tendons and steel cables
- Movement across surface cracks and joints
- Closures in underground excavations, tunnels, etc.
- Displacements associated with landslides
- Movement of boulders, snow, etc. on unstable slopes



• Model 4420 Crackmeter installation.

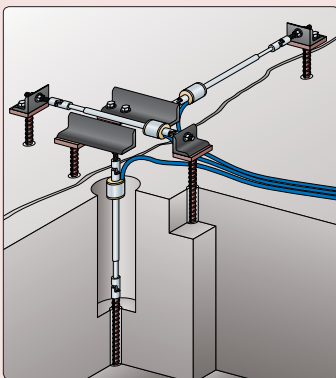

• Three Model 4420 Crackmeters configured as a single 3-D Crackmeter.



• Model 4410 Strandmeter (front), Model 4400 Embedment Jointmeter (center) and Model 4420 Crackmeter (rear).

### Operating Principle

Geokon vibrating wire displacement transducers are designed to measure displacements across joints and cracks in concrete, rock, soil and structural members.

In essence, the transducer consists of a vibrating wire in series with a tension spring. Displacements are accommodated by a stretching of the tension spring, which produces a commensurate increase in wire tension.

The wire and spring are connected to a free-sliding rod which protrudes from, and is free to slide inside, a protective outer tube. An o-ring seal prevents water from entering.

The frequency signal is transmitted through the cable to the readout location, conditioned, and displayed on portable readouts or dataloggers.

### Advantages and Limitations

The 4400 Series Displacement Transducers are fabricated entirely from stainless steel and are waterproof to 1.75 MPa, which, coupled with their excellent long-term stability, guarantees reliability and performance in even the harshest environments.

An advantage of vibrating wire displacement transducers over more conventional linear potentiometers (or LVDT's) lies mainly in the use of a frequency, rather than a voltage, as the output signal. Frequencies may be transmitted over long lengths of electrical cable without appreciable degradation caused by variations in cable resistance or leakage to ground. This allows for a readout location that may be over a thousand meters from the transducer.

Thermistors are provided with all transducers for temperature measurement.

### Model 4400 Embedment Jointmeter



● Model 4400 Embedment Jointmeter shown with socket removed.

The Model 4400 is designed for use in construction joints; e.g. between lifts in concrete dams. In use, a socket is placed in the first lift of concrete and, when the forms are removed, a protective plug is pulled from the socket. The gage is then screwed into the socket, extended slightly and then concreted into the next lift. Any opening of the joint is then measured by the gage which is firmly anchored in each lift. The sensing gage itself, is smaller than the protective housing, and a degree of shearing motion is allowed for by the use of ball-joint connections on the gage.

A tripolar plasma surge arrester is located inside the housing and provides protection from electrical transients such as those that may be induced by lightning.

### Model 4410 Strandmeter



● Model 4410 Strandmeter.

The Model 4410 Strandmeter is designed to measure strains in tendons and steel cables, including bridge tendons, cable stays, ground anchors, tiebacks, etc. Two clamps at each end of the strandmeter hold it firmly onto the cable. Various size clamps are available.

### Model 4420 Crackmeter



● Model 4420 Crackmeter.

The Model 4420 Crackmeters are designed to measure movement across joints such as construction joints in buildings, bridges, pipelines, dams, etc.; tension cracks and joints in rock and concrete.

The ends of the sensor are attached to anchors (with ball joints) that have been grouted, bolted, welded or bonded on opposite sides of the crack or fissure to be monitored. 3-D mounting brackets, which allow measurement of displacements in three orthogonal directions, and special clamps for attachment to a variety of earth reinforcements and geogrids, are also available.

Special versions are offered for underwater use, where water pressures exceed 1.7 MPa, and for use in cryogenic or elevated temperature regimes.

### Model 4422 Micro Crackmeter



● Model 4422 Micro Crackmeter.

The Model 4422 is a miniature crackmeter intended to measure displacements across surface cracks and joints. It has been specially designed for applications where access is limited and/or where monitoring instrumentation is to be as unobtrusive as possible (e.g. on historical structures or buildings).

### Model 4425 Convergence Meter



● Model 4425 Convergence Meter.

The Model 4425 Convergence Meter is designed to detect deformation in tunnels and underground caverns by measuring the contraction (or elongation) between 2 anchor points fixed in the walls of the tunnel or cavern.

The Model 4425 consists of a spring-tensioned vibrating wire transducer assembly, turnbuckle, 6 mm diameter connecting rods (stainless steel, fiberglass or graphite), rod clamp, and a pair of anchor points. Changes in distance between the 2 anchors are conveyed by the connecting rods and measured by the transducer.

The Model 4425 can operate in horizontal, inclined or vertical orientations. In areas where construction traffic is expected or where the instrument may be left in an exposed location, some form of protective housing should be considered.

### Model 4427 Long-Range Displacement Meter



● Model 4427 Long-Range Displacement Meter.

The Model 4427 Long-Range Displacement Meter is ideally suited for the measurement of large displacements associated with landslides. The Model 4427 can also be used for monitoring the movement of boulders, snow, etc., on unstable slopes.

The Model 4427 consists of a vibrating wire displacement transducer coupled to a spring motor drive by means of a lead screw. As the cable is pulled, the motor drum rotates and advances the lead screw. Thus the rotation is converted into a linear displacement which is measured by the vibrating wire displacement transducer.

### Model 4430 Deformation Meter



● Model 4430 Deformation Meter.

The Model 4430 Deformation Meter is designed to measure axial strains or deformations in boreholes in rock, concrete or soil. It can also be embedded in soils in embankments such as earth dams and highway fills. The Model 4430 can be installed in series to give a total deformation profile along a particular axis. Base lengths of the gage can vary from a minimum of 1 meter to over 25 meters.

When used in rock in horizontal or inclined downward boreholes, grouting is the most common method of installation. In vertical boreholes, a special grouting apparatus and hydraulic or snap-ring anchors are required. Direct placement or pre-wiring to a rebar cage allows use in concrete.

### Model 4450 Displacement Transducer

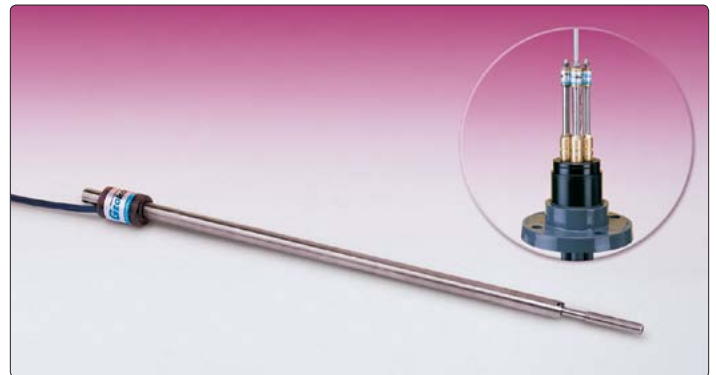

● Model 4450 Displacement Transducer and Extensometer Head Assembly (inset).

The Model 4450 Displacement Transducer provides remote readout capability for Borehole Extensometers (see the Geokon Model A-3, A-4, A-5, A-6 Rod-Type Borehole Extensometers data sheet for more information). They are particularly useful where other types of vibrating wire sensors are used and/or for installations where long cable runs are required.

The Model 4450 can also be installed between borehole anchors, in conjunction with the requisite length connecting rod, to provide a permanent, in-place incremental extensometer (contact Geokon for details).

## Technical Specifications

Model	Standard Ranges <sup>1</sup>	Resolution	Accuracy	Nonlinearity	Temperature Range <sup>1</sup>	Dimensions
<b>4400 Embedment Jointmeter</b>	12.5, 25, 50, 100 mm	0.025% F.S.	±0.1% F.S.	< 0.5% F.S.	-20°C to +80°C	Length: 406 mm Flange Diameter: 51 mm
<b>4410 Strandmeter</b>	3 mm (15,000 µε)	< 5 µε	±0.1% F.S.	< 0.5% F.S.	-20°C to +80°C	Length: 203 mm Clamp Width: 45 mm
<b>4420 Crackmeter</b>	12.5, 25, 50, 100, 150 mm	0.025% F.S.	±0.1% F.S.	< 0.5% F.S.	-20°C to +80°C	Lengths: 318, 362, 527 mm Coil Diameter: 25 mm
<b>4422 Micro Crackmeter</b>	6 mm (±3 mm)	0.001 mm	±0.1% F.S.	< 0.5% F.S.	-20°C to +80°C	Length: 120 mm Diameter: 7.9 mm
<b>4425 Convergence Meter</b>	25, 50, 100, 150 mm	0.025% F.S.	±0.1% F.S.	< 0.5% F.S.	-20°C to +80°C	Transducer Lengths: 356, 508, 838 mm Transducer Diameter: 25 mm
<b>4427 Long-Range Displacement Meter</b>	1, 2 m (without resetting)	0.025% F.S.	±1.0% F.S.	—	-30°C to +60°C	Enclosure (L × W × H): 610 × 152 × 152 mm
<b>4430 Deformation Meter</b>	12.5, 25, 50, 100 mm	0.02% F.S.	±0.1% F.S.	< 0.5% F.S.	-20°C to +80°C	Length: varies Flange Diameter: 50 mm
<b>4450 Displacement Transducer</b>	12.5, 50, 100, 150, 300 mm	0.02% F.S.	±0.1% F.S.	< 0.5% F.S.	-20°C to +80°C	Lengths: 210, 212, 270, 410 mm Coil Diameter: 19 mm

<sup>1</sup>Other ranges available on request.



Geokon, Incorporated  
48 Spencer Street  
Lebanon, NH 03766  
USA

1 • 603 • 448 • 1562  
1 • 603 • 448 • 3216  
geokon@geokon.com  
www.geokon.com

