



The World Leader in Vibrating Wire Technology

48 Spencer Street
Lebanon, NH 03766, USA
Tel: 603•448•1562
Fax: 603•448•3216
E-mail: geokon@geokon.com
<http://www.geokon.com>

Installation Manual

Model 6350

Vibrating Wire Tiltmeter



No part of this instruction manual may be reproduced, by any means, without the written consent of Geokon, Inc.

The information contained herein is believed to be accurate and reliable. However, Geokon, Inc. assumes no responsibility for errors, omissions or misinterpretation. The information herein is subject to change without notification.

Copyright © 1995, 1996, 2007, 2009 by Geokon, Inc.
(Doc Rev L, 06/09)

Warranty Statement

Geokon, Inc. warrants its products to be free of defects in materials and workmanship, under normal use and service for a period of 13 months from date of purchase. If the unit should malfunction, it must be returned to the factory for evaluation, freight prepaid. Upon examination by Geokon, if the unit is found to be defective, it will be repaired or replaced at no charge. However, the WARRANTY is VOID if the unit shows evidence of having been tampered with or shows evidence of being damaged as a result of excessive corrosion or current, heat, moisture or vibration, improper specification, misapplication, misuse or other operating conditions outside of Geokon's control. Components which wear or which are damaged by misuse are not warranted. This includes fuses and batteries.

Geokon manufactures scientific instruments whose misuse is potentially dangerous. The instruments are intended to be installed and used only by qualified personnel. There are no warranties except as stated herein. There are no other warranties, expressed or implied, including but not limited to the implied warranties of merchantability and of fitness for a particular purpose. Geokon, Inc. is not responsible for any damages or losses caused to other equipment, whether direct, indirect, incidental, special or consequential which the purchaser may experience as a result of the installation or use of the product. The buyer's sole remedy for any breach of this agreement by Geokon, Inc. or any breach of any warranty by Geokon, Inc. shall not exceed the purchase price paid by the purchaser to Geokon, Inc. for the unit or units, or equipment directly affected by such breach. Under no circumstances will Geokon reimburse the claimant for loss incurred in removing and/or reinstalling equipment.

Every precaution for accuracy has been taken in the preparation of manuals and/or software, however, Geokon, Inc. neither assumes responsibility for any omissions or errors that may appear nor assumes liability for any damages or losses that result from the use of the products in accordance with the information contained in the manual or software.

TABLE of CONTENTS

1. INTRODUCTION	1
1.1. THEORY OF OPERATION	1
1.2. TILT SENSOR CONSTRUCTION	2
2. INSTALLATION	3
2.1. PRELIMINARY TESTS	3
2.2. INSTALLATION INSTRUCTIONS	3
<i>Uniaxial Installation Instructions</i>	<i>4</i>
<i>Biaxial Installation Instructions</i>	<i>5</i>
2.3. FLUID DAMPING	6
2.4. SPLICING AND JUNCTION BOXES	6
2.5. LIGHTNING PROTECTION	7
3. TAKING READINGS	8
3.1. OPERATION OF THE GK-401 READOUT BOX	8
3.2. OPERATION OF THE GK-403 READOUT BOX	8
3.3. OPERATION OF THE GK404 READOUT BOX	8
3.4. MICRO-10 DATALOGGER	9
3.5. MEASURING TEMPERATURE	9
4. DATA REDUCTION	10
4.1. TILT CALCULATION	10
4.2. TEMPERATURE CORRECTION	10
5. TROUBLESHOOTING	12
APPENDIX A - SPECIFICATIONS	13
A.1. VIBRATING WIRE TILT SENSOR	13
A.2. THERMISTOR (SEE APPENDIX B ALSO)	13
APPENDIX B - THERMISTOR TEMPERATURE DERIVATION	14

LIST of FIGURES, TABLES and EQUATIONS

FIGURE 1 - MODEL 6350 UNIAXIAL TILTMETER INSTALLATION	1
FIGURE 2 - MODEL 6350 TILT SENSOR	2
FIGURE 3 - TILTMETER MOUNTING BRACKETS.....	3
FIGURE 4 - UNIAXIAL TILTMETER INSTALLATION DETAILS.....	4
FIGURE 5 - BIAxIAL TILTMETER INSTALLATION DETAILS	5
FIGURE 6 - LIGHTNING PROTECTION SCHEME	7
FIGURE 6 - SAMPLE MODEL 6350 CALIBRATION SHEET	11
EQUATION B-1 CONVERT THERMISTOR RESISTANCE TO TEMPERATURE.....	14
TABLE B-1 THERMISTOR RESISTANCE VERSUS TEMPERATURE	14

1. INTRODUCTION

1.1. Theory of Operation

The Geokon Model 6350 Vibrating Wire Tiltmeter is designed for permanent long-term monitoring of changes in tilt of structures such as dams, embankments, foundation walls and the like. The basic principle is the utilization of tilt sensors attached to the structure being studied to make accurate measurement of inclination. See Figure 1.

Two brackets are available, one to measure tilt uniaxially the other biaxially.

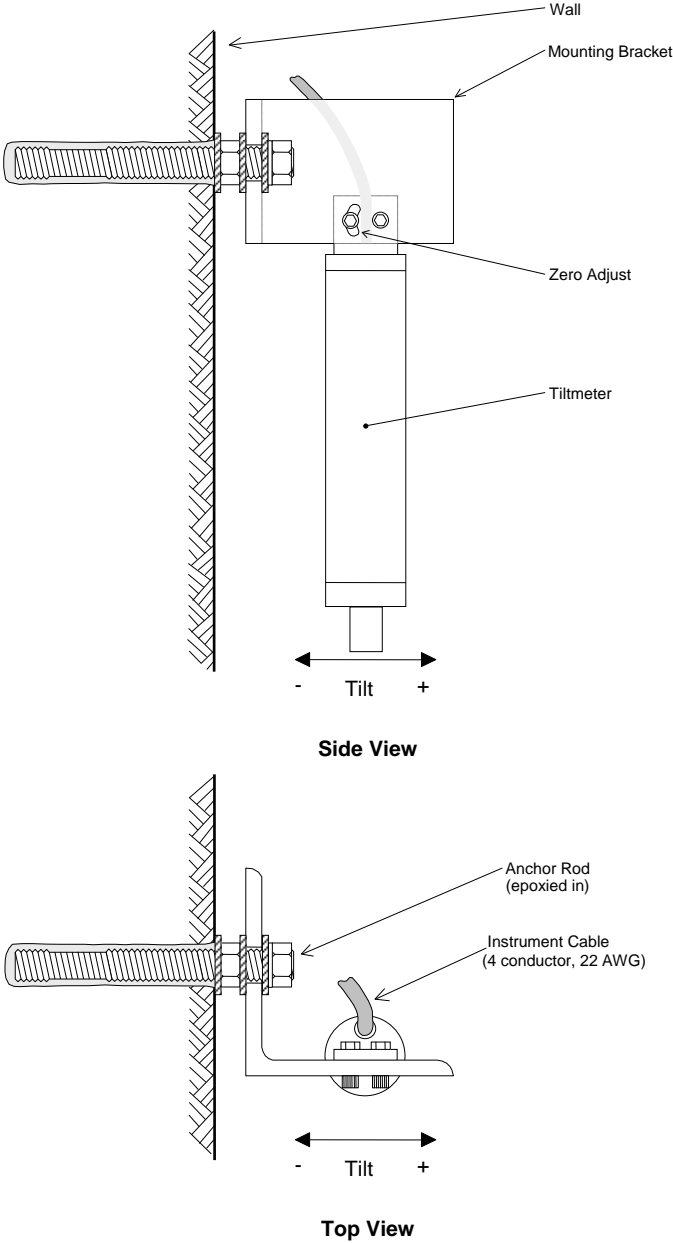

Figure 1 - Model 6350 Uniaxial Tiltmeter Installation

1.2. Tilt Sensor Construction

The sensor comprises a pendulous mass which is supported by a vibrating wire strain gage and an elastic hinge. See Figure 2. The strain gage senses the changes in force caused by rotation of the center of gravity of the mass. The mass and sensor are enclosed in a waterproof housing which includes components for connecting the sensor to the mounting bracket. The housing is constructed using stainless steel tubing to minimize the effects of corrosion. Biaxial systems use a mounting bracket to mount two transducers at 90° to each other. In environments subject to vibrations a damping fluid can be used, as shown in the figure below.

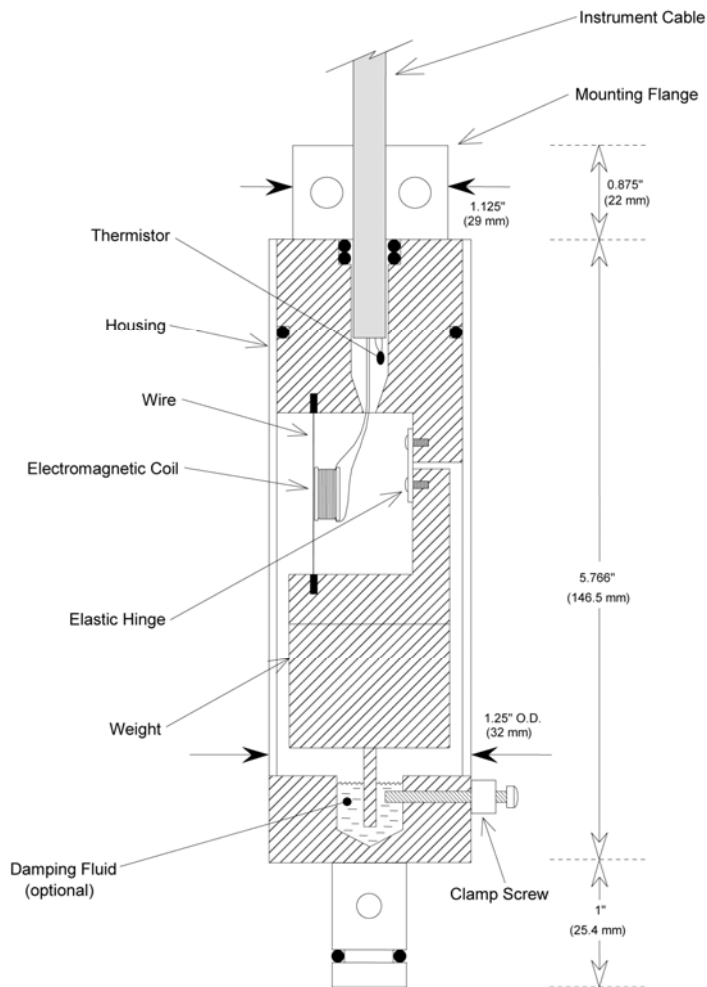

Figure 2 - Model 6350 Tilt Sensor

To prevent damage during shipment the tilt sensors are locked in place by means of a slotted-head locking clamp screw. This slotted-head locking clamp screw must be removed and replaced by a Phillips-head seal screw, (provided in a zip-lock bag)), to render the tiltmeter operative.

2. INSTALLATION

2.1. Preliminary Tests

Prior to installation, the sensors need to be checked for proper operation. Each tilt sensor is supplied with a calibration sheet which shows the relationship between readout digits and inclination. The tilt sensor electrical leads (usually the red and black leads) are connected to a readout box (see section 3) and the current reading compared to the calibration readings. After backing-off the clamp screw 3 full turns, carefully hold the sensor in a vertical position and observe the reading. It will take a few seconds to come to equilibrium and the sensor must be held in a steady position. The readings should be in the range of the factory reading, but will vary according to inclination. The indicated temperature should be close to ambient.

Note: Vibrating wire tilt sensors are shock sensitive and severe shocks can cause a permanent offset or even break the suspension. (The unit will not survive a 2 ft. (.5 m) drop onto a hard surface.) When transporting the tiltmeter tighten the locking clamp screw.

Checks of electrical continuity can also be made using an ohmmeter. Resistance between the gage leads should be approximately 180Ω , ± 10 ohms. Remember to add cable resistance when checking (22 AWG stranded copper leads are approximately $14.7\Omega/1000'$ or $48.5\Omega/\text{km}$, multiply by 2 for both directions). Between the green and white should be approximately 3000 ohms at 25° (see Table B-1), and between any conductor and the shield should exceed 2 megohm.

2.2. Installation Instructions

Two mounting brackets are available for the Model 6350. One is designed for uniaxial tilt measurements the other for biaxial. See Figure 3. Also, two types of bracket mounting hardware are available. The uniaxial tiltmeter installation instructions describe the use of the epoxied or grouted anchor rod while the biaxial instructions describe the drop-in anchor.

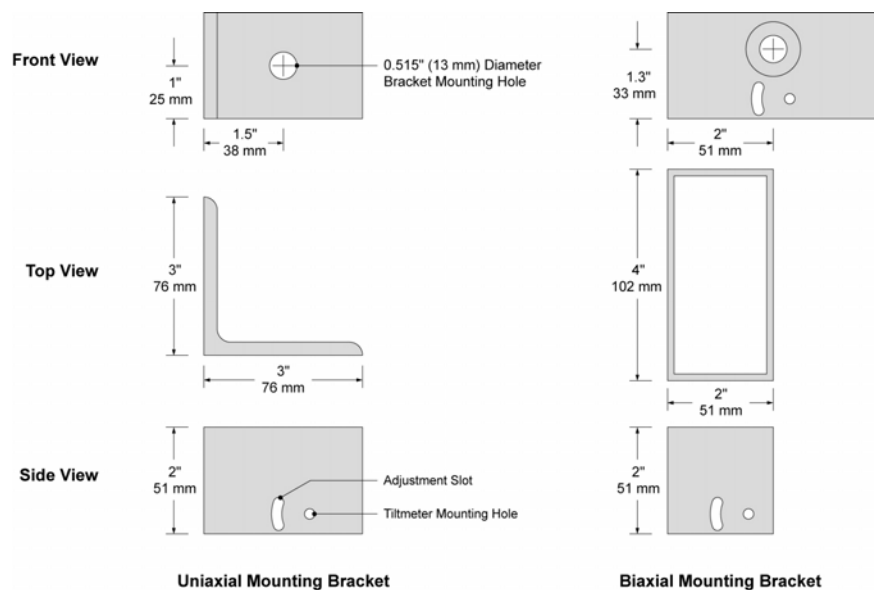

Figure 3 - Tiltmeter Mounting Brackets

Uniaxial Installation Instructions

1. The first step is to install the uniaxial mounting bracket (see Figure 3) which is designed for mounting on vertical walls.

Mark the location and drill using a hammer drill a ½" (12 mm) hole approximately 4" (100 mm) deep. Clean the hole thoroughly, blowing out with compressed air if possible. Mix the grout or epoxy and fill the hole. Push the ½-13 threaded anchor rod into the hole, use a hammer if necessary to reach the bottom. Let the anchor rod set before continuing the installation. After setting, attach the mounting bracket to the bolt using the supplied hardware as illustrated in Figure 4. Use a bubble level or other leveling device to align the bracket vertically to the wall.

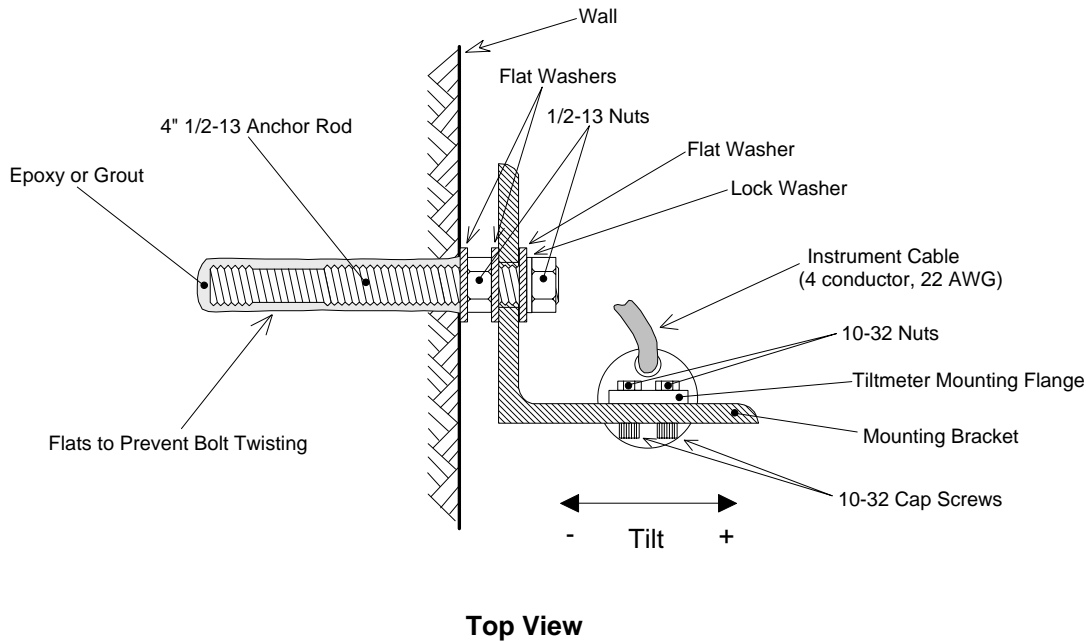

Figure 4 - Uniaxial Tiltmeter Installation Details

2. Now, the sensor may be installed. Attach the tiltmeter to the mounting bracket using the supplied 10-32 cap screws, washers and nuts. **Remove the slotted-head locking clamp screw completely and replace with the Phillips-head seal screw (provided in a zip-lock bag). This is very important if the sensor is to remain waterproof.** Do not tighten the cap screws yet. Attach a portable readout such as the GK-401 or GK-403 (see Section 3 for readout instructions) and observe the reading. Adjust the sensor in the slot of the mounting bracket while observing the readout until the tiltmeter reads within ± 50 digits of the zero reading as shown on the calibration sheet (sample, Figure 5) supplied with the sensor. When the desired reading is reached, tighten the cap screws to secure the tiltmeter in place. Check the reading again after tightening to make sure it still reads within ± 50 digits of the zero reading.

If the tiltmeter is installed in an exposed location in a construction area and/or if the installation is in direct sunlight it should be covered with a protective enclosure and/or insulation.

Biaxial Installation Instructions

1. The first step is to install the biaxial mounting bracket (see Figure 3) which is designed for mounting on vertical walls.

Mark the location and drill using a hammer drill a ½" (12 mm) hole approximately 1½" (37 mm) deep. Clean the hole thoroughly, blowing out with compressed air if possible. Insert the 3/8" drop-in anchor with setting pin into the hole. The threaded end should be closest to the opening. Using the supplied setting pin tool and a hammer, set the anchor with 2 or 3 sharp blows on the setting pin. Thread the supplied 3/8-16 anchor rod into the anchor. Attach the mounting bracket to the bolt using the supplied hardware as illustrated in Figure 5. Use a bubble level or other leveling device to align the bracket vertically to the wall.

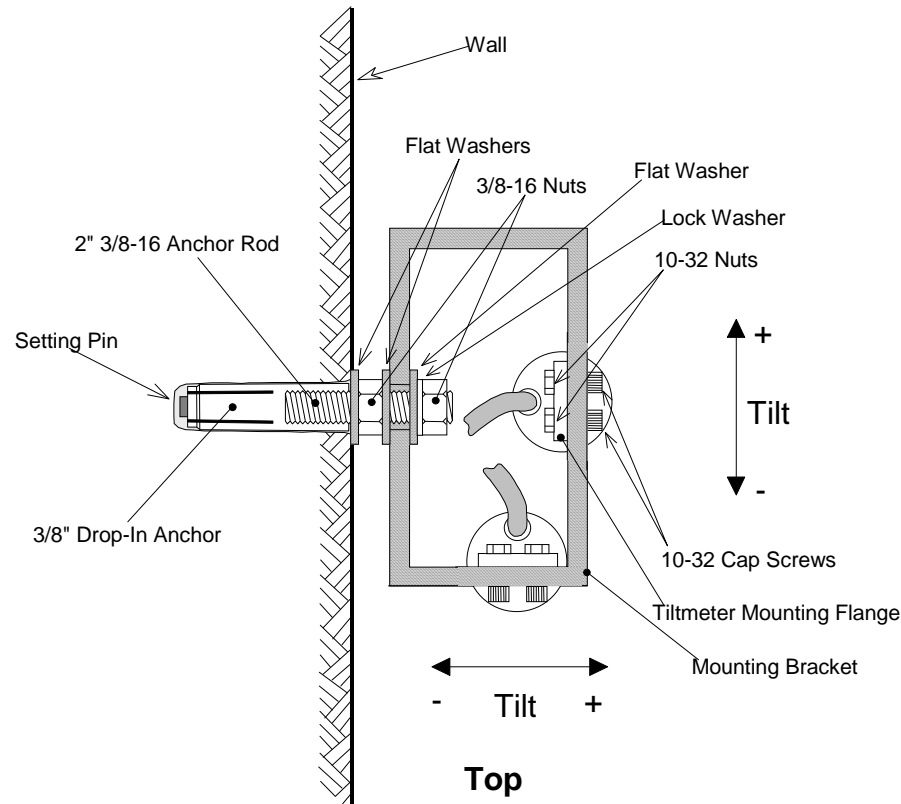

Figure 5 - Biaxial Tiltmeter Installation Details

2. Now, the sensors may be installed. Attach the tiltmeters to the mounting bracket using the supplied 10-32 cap screws, washers and nuts. **Remove the slotted-head locking clamp screw completely and replace with the Phillips-head seal screw provided. This is very important if the sensor is to remain waterproof.** Do not tighten the cap screws yet. Attach a portable readout such as the GK-401 or GK-403 (see Section 3 for readout instructions) and observe the reading. Adjust each sensor in their slots of the mounting bracket while observing the readout until the tiltmeter reads within ± 50 digits of the zero reading as shown on the calibration sheet (sample, Figure 5) supplied with each sensor. When the desired reading is reached, tighten the cap screws to secure the tiltmeter in place. Check the reading again after tightening to make sure it still reads within ± 50 digits of the zero reading.

If the tiltmeters are installed in an exposed location in a construction area and/or if the installation is in direct sunlight it should be covered with a protective enclosure and/or insulation.

2.3. Fluid Damping

The vibrating wire tilt sensor acts as a self-damping system when used in vibration free environments. When external ground or structural vibrations exceed a certain threshold, the pendulous mass will continue to "swing" and stable readings may not be possible. In such cases, additional damping can be achieved by adding a viscous damping fluid to a small reservoir contained in the sensor. A thin, wide "paddle" is connected to the mass and when the fluid is added the pendulum is damped by the action of the paddle in the damping fluid (see Figure 2).

Most in-place tiltmeter installations will not require this fluid. However, if the instrument gives unstable outputs, or it is known that the structure is constantly vibrating, the fluid can be added. The fluid is a very high viscosity silicone oil which must be injected into the sensor with a syringe.

The sensor must be held upright during the injection of the fluid and at all times following the injection. This makes it necessary to perform this operation in the field. The following applies for a typical in-place installation.

1. Remove the seal screw on the bottom side of the sensor. See Figure 2.(clamp screw)
2. Using the syringe applied, first pull the piston from the syringe and squeeze the silicone from the tube into the syringe. Replace the piston and start the fluid out of the "needle" end.
3. Now, inject 2.00cc into the hole in the sensor. Immediately following this operation, the seal screw should be replaced in the sensor.
4. The sensor may now be attached to the mounting bracket.

2.4. Splicing and Junction Boxes

Because the vibrating wire output signal is a frequency rather than current or voltage, variations in cable resistance have little effect on gage readings and, therefore, splicing of cables has little effect and, in some case, may be beneficial. For example, if a number of tiltmeters are installed in a cluster, and the distance from the cluster to the terminal box or datalogger is great, a splice could be made to connect the individual cables to a single multi-conductor cable. This multiconductor cable would then be run to the readout station.

The cable used for making splices should be a high quality twisted pair type with 100% shielding (with integral shield drain wire). When splicing, it is very important that the shield drain wires be spliced together! Splice kits recommended by Geokon (i.e. 3M Scotchcast™, model 82-A1) incorporate casts placed around the splice then filled with epoxy to waterproof the connections. When properly made, this type of splice is equal or superior to the cable itself in strength and electrical properties. Contact Geokon for splicing materials and additional cable splicing instructions.

Junction boxes and terminal boxes are available from Geokon for all types of applications. In addition, portable readout equipment and datalogging hardware are available. Contact Geokon for specific application information.

2.5. Lightning Protection

The Model 6350 Tiltmeter, unlike numerous other types of instrumentation available from Geokon, does not have any integral lightning protection components, i.e. transzorb or plasma surge arrestors. Usually this is not a problem. However, if the instrument cable is exposed, it may be advisable to install lightning protection components, as the transient could travel down the cable to the gage and possibly destroy it.

Note the following suggestions;

- If the tiltmeter is connected to a terminal box or multiplexer, components such as plasma surge arrestors (spark gaps) may be installed in the terminal box/multiplexer to provide a measure of transient protection. Terminal boxes and multiplexers available from Geokon provide locations for installation of these components.
- Lightning arrestor boards and enclosures are available from Geokon that install near the instrument. The enclosure has a removable top so, in the event the protection board (LAB-3) is damaged, the user may service the components (or replace the board). A connection is made between this enclosure and earth ground to facilitate the passing of transients away from the gage. See Figure 6. Consult the factory for additional information on these or alternate lightning protection schemes.
- Plasma surge arrestors can be epoxy potted into the gage cable close to the sensor. A ground strap would connect the surge arrestor to earth ground, either a grounding stake or other suitable earth ground.

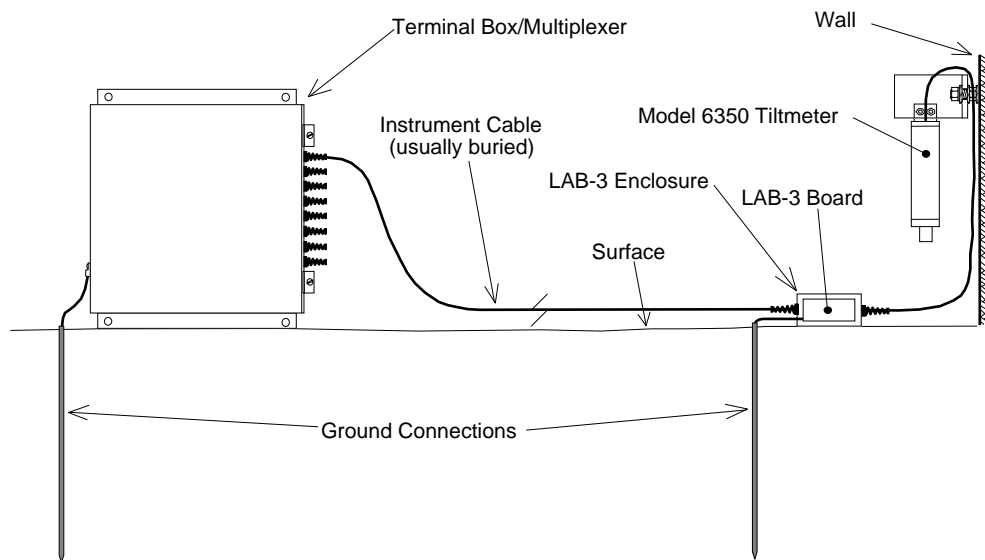

Figure 6 - Lightning Protection Scheme

3. TAKING READINGS

3.1. Operation of the GK-401 Readout Box

The GK-401 is a basic readout for all vibrating wire gages.

Connect the Readout using the flying leads or in the case of a terminal station, with a connector. The red and black clips are for the vibrating wire gage, the green or blue clip for the shield drain wire. The GK-401 cannot read the thermistor (see Section 3.4).

1. Turn the display selector to position "B". Readout is in digits (Equation 1).
2. Turn the unit on and a reading will appear in the front display window. The last digit may change one or two digits while reading. Record the value displayed. If zeros are displayed or the reading is unstable see section 5 for troubleshooting suggestions.
3. The unit will automatically turn itself off after approximately 4 minutes to conserve power.

3.2. Operation of the GK-403 Readout Box

The GK-403 can store gage readings and also apply calibration factors to convert readings to engineering units. Consult the GK-403 Instruction Manual for additional information on Mode "G" of the Readout. The following instructions will explain taking gage measurements using Mode "B".

Connect the Readout using the flying leads or in the case of a terminal station, with a connector. The red and black clips are for the vibrating wire gage, the white and green clips are for the thermistor and the blue for the shield drain wire.

1. Turn the display selector to position "B". Readout is in digits (Equation 1).
2. Turn the unit on and a reading will appear in the front display window. The last digit may change one or two digits while reading. Press the "Store" button to record the value displayed. If the no reading displays or the reading is unstable see section 5 for troubleshooting suggestions. The thermistor will be read and output directly in degrees centigrade.
3. The unit will automatically turn itself off after approximately 2 minutes to conserve power.

3.3 Operation of the GK404 Readout Box

The GK404 is a palm sized readout box which displays the Vibrating wire value and the temperature in degrees centigrade.

The GK-404 Vibrating Wire Readout arrives with a patch cord for connecting to the vibrating wire gages. One end will consist of a 5-pin plug for connecting to the respective socket on the bottom of the GK-404 enclosure. The other end will consist of 5 leads terminated with alligator clips. Note the colors of the alligator clips are red, black, green, white and blue. The colors represent the positive vibrating wire gage lead (red), negative vibrating wire gage lead (black), positive thermistor lead (green), negative thermistor lead (white) and transducer cable drain wire

(blue). The clips should be connected to their respectively colored leads from the vibrating wire gage cable.

Use the **POS** (Position) button to select position **B** and the **MODE** button to select **Dg** (digits). Other functions can be selected as described in the GK404 Manual.

The GK-404 will continue to take measurements and display the readings until the OFF button is pushed, or if enabled, when the automatic Power-Off timer shuts the GK-404 off.

The GK-404 continuously monitors the status of the (2) 1.5V AA cells, and when their combined voltage drops to 2V, the message **Batteries Low** is displayed on the screen. A fresh set of 1.5V AA batteries should be installed at this point

3.4. MICRO-10 Datalogger

The following parameters are recommended when using the Model 6350 with the MICRO-10 datalogger or any other CR10 based datalogger:

Excitation - The 2.5V excitation directly off the wiring panel is ideal for these sensors. The 5 volt supply from the AVW-1 and AVW-4 modules is also usable, but the 12V excitation should be avoided as it tends to overdrive the sensor. The default excitation voltage used in MICRO-10 systems is 5V.

Excitation Frequency - The starting and ending frequencies of the excitation sweep should be kept in a relatively narrow band for these sensors to maximize the stability and resolution of the output. The exact values can be calculated for a given sensor from the supplied calibration sheet. Ideally one could calculate settings by taking an initial reading and then setting the starting frequency to 200 Hz below and the ending frequency 200 Hz above. Alternately, the low end frequency sweep setting should be set to 14 (1400 Hz), the high end, 35 (3500 Hz).

3.5. Measuring Temperature

Each vibrating wire tiltmeter is equipped with a thermistor for reading temperature. The thermistor gives a varying resistance output as the temperature changes. Usually the white and green leads are connected to the internal thermistor.

1. Connect an ohmmeter to the two thermistor leads coming from the tilt sensor. (Since the resistance changes with temperature are so large, the effect of cable resistance is usually insignificant.)
2. Look up the temperature for the measured resistance in Table B-1. Alternately the temperature could be calculated using Equation B-1.

Note: The GK-403 readout box will read the thermistor and display temperature in °C automatically.

4. DATA REDUCTION

4.1. Tilt Calculation

Tilts are measured in digits on Position B of either the GK-401 or GK-403 Readout Box. The relationship between these digits and the change of the angle of inclination (tilt) is given by the equation:

$$\Delta\theta = (R_1 - R_0) G \quad \text{degrees}$$

Where:

R_1 is the current reading in digits

R_0 is the initial reading in digits

and G is the Calibration Factor in degrees/digit

The linear equation works very well for tilt angles of less than two degrees. More than this and the linearity errors increase. The error incurred by using the linear equation is shown on the calibration chart.

For better accuracy at larger inclinations use the polynomial equation:

$$\theta = R^2A + RB + C$$

Where A , B and C are the coefficients supplied on the calibration sheet. Calculate θ for $R = R_1$ and $R = R_0$ then subtract to find the difference $\Delta\theta$ for $(R_1 - R_0)$.

4.2. Temperature Correction

The Model 6350 Tiltmeter has a very slight temperature sensitivity on the order of -0.5 digit per $^{\circ}\text{C}$ rise, i.e. the reading falls by 0.5 digits for every 1°C rise of temperature. The temperature correction is:

$$+K (T_1 - T_0) \quad \text{degrees}$$

Where $K = 0.5G$

Normally, corrections are not applied for this small effect because the structure being monitored usually is affected to a much greater degree. An important point to note, also, is that sudden changes in temperature will cause both the structure and the Tiltmeter to undergo transitory physical changes, which will show up in the readings. The gage temperature should always be recorded for comparison, and efforts should be made to obtain readings when the instrument and structure are at thermal equilibrium. The best time for this tends to be in the late evening or early morning hours.



48 Spencer St. Lebanon, N.H. 03766 USA

Vibrating Wire Tilt Sensor Calibration

Model Number: 6350Calibration Date: April 26, 2004Serial Number: 04-4472Temperature: 22.9 °CCal. Std. Control #(s): 406, 213, 260, 189, 524, 529, 333

Technician: _____

Inclination (sin)	Inclination (degrees)	* Reading 1st Cycle (digits)	* Reading 2nd Cycle (digits)	* Average Reading (digits)	Error (%FS)	
					Linear	Polynomial
0.0867	4.972	10469	10470	10470	-0.31	0.01
0.0667	3.823	9910	9912	9911	-0.20	0.01
0.0533	3.057	9540	9540	9540	-0.10	-0.02
0.0349	1.998	9023	9022	9023	-0.05	-0.01
0.0175	1.003	8535	8535	8535	-0.03	0.00
0.0087	0.497	8285	8287	8286	-0.04	0.02
0.0042	0.241	8161	8162	8162	-0.01	0.00
0.0000	0.000	8044	8044	8044	0.00	-0.01
-0.0042	-0.241	7926	7923	7925	-0.03	0.01
-0.0087	-0.497	7800	7800	7800	0.00	-0.01
-0.0175	-1.003	7551	7551	7551	-0.01	-0.01
-0.0349	-1.998	7059	7058	7059	-0.09	0.03
-0.0533	-3.057	6537	6536	6537	-0.14	0.00
-0.0667	-3.823	6159	6158	6159	-0.18	-0.02
-0.0867	-4.972	5587	5587	5587	-0.33	0.00

*Readings displayed in GK-401 Position B.

Linear Gage Factor (G): 0.002037 (degrees/ digit)Polynomial Gage Factors: A: 5.084E-09 B: 1.955E-03 C: -16.053Calculated Angle (degrees): Linear, $q = G(R_1 - R_0) + K(T_1 - T_0)$ Polynomial, $q = AR^2 + BR + C$

Wiring Code: Red and Black: Gage White and Green: Thermistor Bare: Shield

The above instrument was found to be in tolerance in all operating ranges.

The above named instrument has been calibrated by comparison with standards traceable to the NIST, in compliance with ANSI Z540-1.

This report shall not be reproduced except in full without written permission of Geokon Inc.

Figure 6 - Sample Model 6350 Calibration Sheet

5. TROUBLESHOOTING

Maintenance and troubleshooting of the vibrating wire tilt sensors used in the Model 6350 Tiltmeter are confined to periodic checks of cable connections. The sensors are sealed and there are no user-serviceable parts.

Consult the following list of problems and possible solutions should difficulties arise. Consult the factory for additional troubleshooting help.

Symptom: Tiltmeter Readings are Unstable

- ✓ Is the readout box position set correctly? If using a datalogger to record readings automatically are the swept frequency excitation settings correct? Channel A of the GK-401 and GK-403 can be used to read the tilt sensor. To convert the Channel A period display to digits use Equation 1.
- ✓ Is there a source of electrical noise nearby? Most probable sources of electrical noise are motors, generators and antennas. Make sure the shield drain wire is connected to ground whether using a portable readout or datalogger. If using the GK-401 Readout connect the clip with the green boot to the bare shield drain wire of the tilt sensor cable. If using the GK-403 connect the clip with the blue boot to the shield drain wire.
- ✓ Does the readout work with another tilt sensor? If not, the readout may have a low battery or be malfunctioning.

Symptom: Tiltmeter Fails to Read

- ✓ Is the cable cut or crushed? This can be checked with an ohmmeter. Nominal resistance between the two gage leads (usually red and black leads) is $180\Omega, \pm 10\Omega$. Remember to add cable resistance when checking (22 AWG stranded copper leads are approximately $14.7\Omega/1000'$ or $48.5\Omega/\text{km}$, multiply by 2 for both directions). If the resistance reads infinite, or very high (megohms), a cut wire must be suspected. If the resistance reads very low ($<20\Omega$) a short in the cable is likely.
- ✓ Does the readout or datalogger work with another tilt sensor? If not, the readout or datalogger may be malfunctioning.

Symptom: Thermistor resistance is too high.

- ✓ Is there an open circuit? Check all connections, terminals and plugs. If a cut is located in the cable, splice according to instructions in Section 2.4.

Symptom: Thermistor resistance is too low.

- ✓ Is there a short? Check all connections, terminals and plugs. If a short is located in the cable, splice according to instructions in Section 2.4.
- ✓ Water may have penetrated the interior of the tilt sensor. There is no remedial action.

APPENDIX A - SPECIFICATIONS

A.1. Vibrating Wire Tilt Sensor

Model:	6350
Range: ¹	±10°
Resolution: ²	8 arc seconds
Accuracy: ³	0.1% FSR
Linearity:	1.5% FSR
Thermal Zero Shift:	±0.01% FS/°C
Operating Temperature	-40 to +80° C -40 to 175° F
Operating Frequency:	1400-3500 Hz
Coil Resistance:	180 Ω
Diameter:	1.250", 32 mm
Length:	7.375", 187 mm
Weight:	1.5 lbs., 0.7 kg.
Materials:	304 Stainless Steel
Electrical Cable:	2 twisted pair (4 conductor) 22 AWG Foil shield, PVC jacket, nominal OD=6.3 mm (0.250")

Table A-1 Model 6350 Tilt Sensor Specifications

Notes:

¹ Consult the factory for other ranges.

² Depends on readout equipment. With averaging techniques it is possible to achieve 1 arc second

³ Derived using 2nd order polynomial.

A.2. Thermistor (see Appendix B also)

Range: -80 to +150° C

Accuracy: ±0.5° C

APPENDIX B - THERMISTOR TEMPERATURE DERIVATION

Thermistor Type: YSI 44005, Dale #1C3001-B3, Alpha #13A3001-B3

Resistance to Temperature Equation:

$$T = \frac{1}{A + B(\ln R) + C(\ln R)^3} - 273.2$$

Equation B-1 Convert Thermistor Resistance to Temperature

Where; T = Temperature in °C.

LnR = Natural Log of Thermistor Resistance

A = 1.4051 × 10⁻³ (coefficients calculated over the -50 to +150° C. span)

B = 2.369 × 10⁻⁴

C = 1.019 × 10⁻⁷

Ohms	Temp	Ohms	Temp	Ohms	Temp	Ohms	Temp	Ohms	Temp
201.1K	-50	16.60K	-10	2417	+30	525.4	+70	153.2	+110
187.3K	-49	15.72K	-9	2317	31	507.8	71	149.0	111
174.5K	-48	14.90K	-8	2221	32	490.9	72	145.0	112
162.7K	-47	14.12K	-7	2130	33	474.7	73	141.1	113
151.7K	-46	13.39K	-6	2042	34	459.0	74	137.2	114
141.6K	-45	12.70K	-5	1959	35	444.0	75	133.6	115
132.2K	-44	12.05K	-4	1880	36	429.5	76	130.0	116
123.5K	-43	11.44K	-3	1805	37	415.6	77	126.5	117
115.4K	-42	10.86K	-2	1733	38	402.2	78	123.2	118
107.9K	-41	10.31K	-1	1664	39	389.3	79	119.9	119
101.0K	-40	9796	0	1598	40	376.9	80	116.8	120
94.48K	-39	9310	+1	1535	41	364.9	81	113.8	121
88.46K	-38	8851	2	1475	42	353.4	82	110.8	122
82.87K	-37	8417	3	1418	43	342.2	83	107.9	123
77.66K	-36	8006	4	1363	44	331.5	84	105.2	124
72.81K	-35	7618	5	1310	45	321.2	85	102.5	125
68.30K	-34	7252	6	1260	46	311.3	86	99.9	126
64.09K	-33	6905	7	1212	47	301.7	87	97.3	127
60.17K	-32	6576	8	1167	48	292.4	88	94.9	128
56.51K	-31	6265	9	1123	49	283.5	89	92.5	129
53.10K	-30	5971	10	1081	50	274.9	90	90.2	130
49.91K	-29	5692	11	1040	51	266.6	91	87.9	131
46.94K	-28	5427	12	1002	52	258.6	92	85.7	132
44.16K	-27	5177	13	965.0	53	250.9	93	83.6	133
41.56K	-26	4939	14	929.6	54	243.4	94	81.6	134
39.13K	-25	4714	15	895.8	55	236.2	95	79.6	135
36.86K	-24	4500	16	863.3	56	229.3	96	77.6	136
34.73K	-23	4297	17	832.2	57	222.6	97	75.8	137
32.74K	-22	4105	18	802.3	58	216.1	98	73.9	138
30.87K	-21	3922	19	773.7	59	209.8	99	72.2	139
29.13K	-20	3748	20	746.3	60	203.8	100	70.4	140
27.49K	-19	3583	21	719.9	61	197.9	101	68.8	141
25.95K	-18	3426	22	694.7	62	192.2	102	67.1	142
24.51K	-17	3277	23	670.4	63	186.8	103	65.5	143
23.16K	-16	3135	24	647.1	64	181.5	104	64.0	144
21.89K	-15	3000	25	624.7	65	176.4	105	62.5	145
20.70K	-14	2872	26	603.3	66	171.4	106	61.1	146
19.58K	-13	2750	27	582.6	67	166.7	107	59.6	147
18.52K	-12	2633	28	562.8	68	162.0	108	58.3	148
17.53K	-11	2523	29	543.7	69	157.6	109	56.8	149
								55.6	150

Table B-1 Thermistor Resistance versus Temperature