



The World Leader in Vibrating Wire Technology

48 Spencer Street
Lebanon, NH 03766, USA
Tel: 603•448•1562
Fax: 603•448•3216
E-mail: geokon@geokon.com
<http://www.geokon.com>

Instruction Manual

Model 6400

Glue-Snap Inclinometer Casing

No part of this instruction manual may be reproduced, by any means, without the written consent of Geokon, Inc.

The information contained herein is believed to be accurate and reliable. However, Geokon, Inc. assumes no responsibility for errors, omissions or misinterpretation. The information herein is subject to change without notification.

Copyright © 2007, 2008 by Geokon, Inc.
(Doc Rev C, 12/08)

Warranty Statement

Geokon, Inc. warrants its products to be free of defects in materials and workmanship, under normal use and service for a period of 13 months from date of purchase. If the unit should malfunction, it must be returned to the factory for evaluation, freight prepaid. Upon examination by Geokon, if the unit is found to be defective, it will be repaired or replaced at no charge. However, the WARRANTY is VOID if the unit shows evidence of having been tampered with or shows evidence of being damaged as a result of excessive corrosion or current, heat, moisture or vibration, improper specification, misapplication, misuse or other operating conditions outside of Geokon's control. Components which wear or which are damaged by misuse are not warranted. This includes fuses and batteries.

Geokon manufactures scientific instruments whose misuse is potentially dangerous. The instruments are intended to be installed and used only by qualified personnel. There are no warranties except as stated herein. There are no other warranties, expressed or implied, including but not limited to the implied warranties of merchantability and of fitness for a particular purpose. Geokon, Inc. is not responsible for any damages or losses caused to other equipment, whether direct, indirect, incidental, special or consequential which the purchaser may experience as a result of the installation or use of the product. The buyer's sole remedy for any breach of this agreement by Geokon, Inc. or any breach of any warranty by Geokon, Inc. shall not exceed the purchase price paid by the purchaser to Geokon, Inc. for the unit or units, or equipment directly affected by such breach. Under no circumstances will Geokon reimburse the claimant for loss incurred in removing and/or reinstalling equipment.

Every precaution for accuracy has been taken in the preparation of manuals and/or software, however, Geokon, Inc. neither assumes responsibility for any omissions or errors that may appear nor assumes liability for any damages or losses that result from the use of the products in accordance with the information contained in the manual or software.

TABLE of CONTENTS

1. FORWARD	1
2. GEOKON GLUE AND SNAP CASING PART NUMBERS.....	1
3. PRE-INSTALLATION	2
4. ASSEMBLY OF GLUE AND SNAP CASING.....	2
4.1 GLUE AND SNAP CASING SECTIONS.....	2
4.2 INSTALLING AN END CAP	3
4.3 ASSEMBLING CASING SECTIONS.....	4
4.4 INSTALLING THE TOP CAP	4
4.5 ASSEMBLING TELESCOPIC SECTIONS.....	5
5. INSTALLING GLUE AND SNAP CASING	6
5.1 INSTALLATION NOTES	6
5.2 INSTALLATION METHODS	7
5.3 CASING BUOYANCY	7
5.4 GROUTING.....	7
6. REPAIRING DAMAGED CASING.....	8
7. INSTALLING CORRUGATED SETTLEMENT SHEATH PIPE	9
8. PROTECTIVE CAPS	10
9. SNAP GLUE INCLINOMETER CASING GROUT ADAPTER & GROUT CASING ANCHOR SUGGESTED INSTALLATION METHOD.....	12

Figures

FIGURE 1 – GEOKON GLUE AND SNAP CASING	3
FIGURE 2 – END CAP JOINT	3
FIGURE 3 – TYPICAL CASING JOINT	4
FIGURE 4 – TOP CAP.....	5
FIGURE 5 – GEOKON GLUE AND SNAP TELESCOPING SECTION	6
FIGURE 6 – GROOVE ALIGNMENT.....	6
FIGURE 7 – CASING PREPARATION	8
FIGURE 8 – GEOKON COUPLING TOOL.....	9
FIGURE 9 – PROTECTIVE CAP	10
FIGURE 10 - GLUE-SNAP CASING REPAIR COUPLER IN PLACE	11

1. Forward

Please note that these instructions are a general indication of typical field practices, and may require modification to suit site-specific applications. This equipment should be installed, maintained, and operated by technically qualified personnel. Any errors or omissions in the installation, data, or data interpretation, are not the responsibility of Geokon, Inc.

2. Geokon Glue and Snap Casing Part Numbers

70 mm (2.75 inch) Casing	Part No.
5 ft. Length	6400-2-5
10 ft. Length	6400-2-10
Top Cap	6400-2T
Bottom Cap	6400-2B
Grout Cap	6400-2G
Telescopic Section	6400-2S

85 mm (3.34 inch) Casing	Part No.
5 ft. Length	6400-3-5
10 ft. Length	6400-3-10
Top Cap	6400-3T
Bottom Cap	6400-3B
Grout Cap	6400-3G
Telescopic Section	6400-3S

3. Pre-Installation

Before beginning the installation, ensure that all equipment, accessories and spares are available:

- Casing and caps
- Spare bottom and top caps
- Spare casing length(s)
- Grout tremie line
- Grout valved bottom cap (if employing this method); c/w spare female grout valve
- Drill rods to weigh casing
- Safety line (if required)
- Repair Coupling and Alignment Tool (if required)
- Clean water supply to ballast casing
- Hand saw
- Casing collar protection (as required)
- Chain or casing clamps
- ABS Premium Cement (**not PVC Cement**)
- ABS/PVC Cleaner

Inspect casing lengths to insure that damage in transit has not occurred. Ensure that the inside of the casing is clean. To ensure the joint and casing interior will remain clean, only remove the protective end caps prior to installing the casing. Store the casing horizontally, fully supported, and out of the sunlight. Number each length, and assemble numerically to avoid errors, and confirm correct depth.

Do not assemble the casing prior to insertion in the borehole.

Drill the borehole as vertical as possible, preferably within 1 degree. Flush the borehole clean, and verify that the borehole is fully open to the bottom.

4. Assembly of Glue and Snap Casing

4.1 Glue and Snap Casing Sections

Each section of casing has a male end with an alignment key, and a lock ring and a female end with a keyway and corresponding lock ring (Figure 1). Casing is installed with the female end facing up. Please note the female ends of the casing have three slots in them. These are stress relief cuts which facilitate the insertion of the male end of the subsequent casing section.

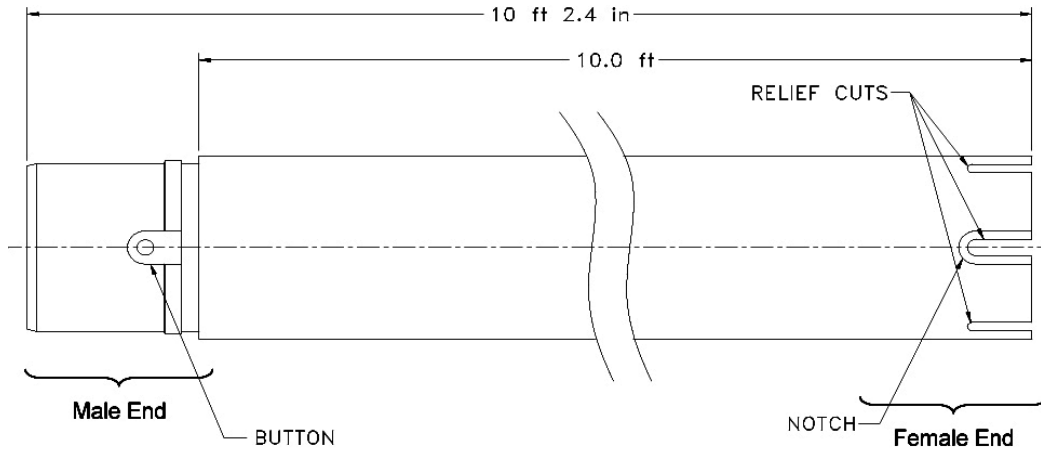

Figure 1 – Geokon Glue and Snap casing

4.2 Installing an End Cap

Before installing the first section of casing in the borehole, an end cap must be installed as indicated in figure 2.

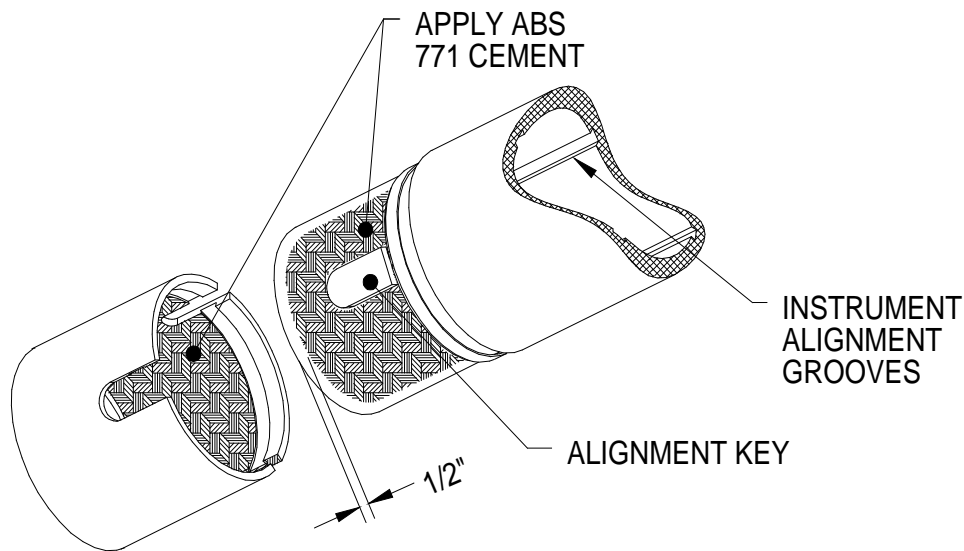

Figure 2 – End Cap Joint

Apply ABS premium cement (**not PVC cement**) Type 771 or 773, in a thin uniform band around the male end of the casing and the inside of the cap. The cement band should cover the majority of the mating surface (Figure 2).

Align the notch on the cap with the key-way on the casing. Slide the cap on without engaging the notch and then rotate it back and forth 90 degrees to spread the cement. Fully engage the notch and key. You will hear a “snap” as the lock ring is seated. Visually ensure proper assembly. If assembly of the joint is difficult, an ABS/PVC cleaner can be used prior to the application of the ABS cement. The cleaner not only cleans the pipe, but also helps to soften the ABS, lessening the force required to complete the joint. Typically, a grout tube will be attached to the first section of casing. Additional grout tubes may be added during installation for multistage grouting.

The casing, with attached cap, can then be lowered into the hole. If applicable, attach a safety line, and a grout tremie line.

4.3 Assembling Casing Sections

Subsequent casing sections in a borehole should be assembled using ABS cement, Type 771 or 773, on the **male end only**. **DO NOT apply cement to the female end.** Applying cement to the female end causes the glue to extrude into the inside of the casing, which can potentially block the grooves. Be sure to apply the glue liberally, ensuring complete coverage of the male end. In each case, the alignment button on the casing should be aligned with the notch in the female end (Figure 3). You will hear a “snap” as the lock ring is seated. Wipe off any excess cement that is pushed out of the joint onto the outside of the casing. If required, the joint can be further sealed by 2” duct tape. If assembly of the joint is difficult, an ABS/PVC cleaner can be used prior to the application of the ABS cement. The cleaner not only cleans the pipe, but helps to soften the ABS lessening the force required to complete the joint.

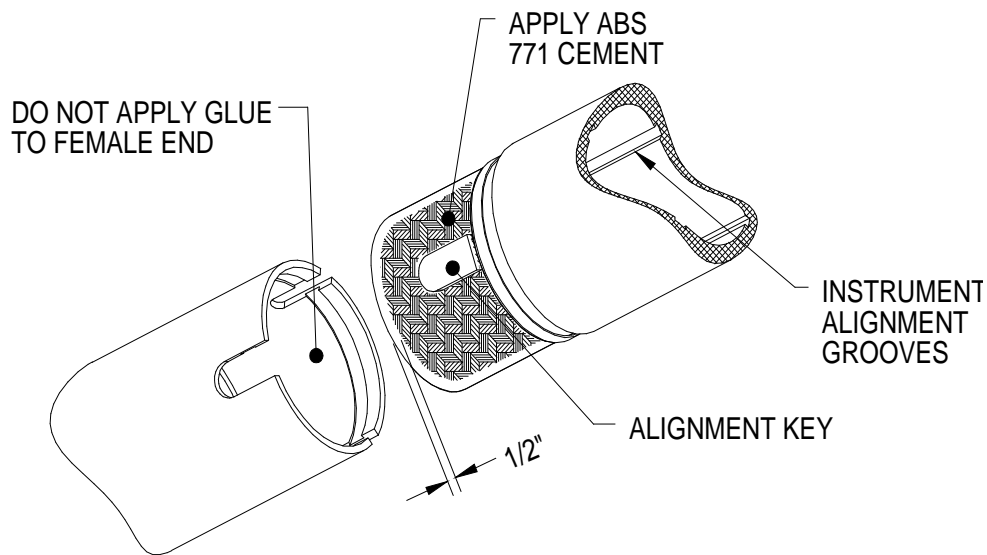

Figure 3 – Typical Casing Joint

4.4 Installing the Top Cap

After all the inclinometer sections have been installed, place a Top Slip Cap over the last piece of casing when finished and/or not in use. Do not cement into place. The cap is provided as a removable protective cover which prevents foreign objects from entering the casing.

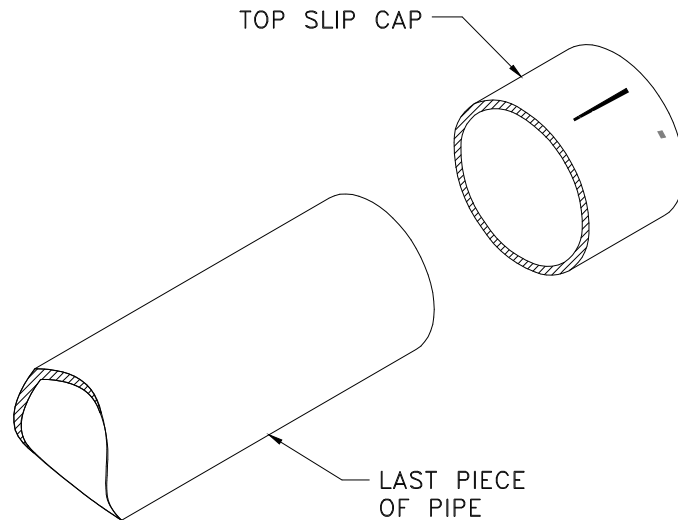

Figure 4 – Top Cap

4.5 Assembling Telescopic Sections

Each telescoping section is 2ft. (24") in length and allows for six inches of compression or extension (Figure 5). Settlement sections may be inserted extended or collapsed, to accommodate the expected settlement/rebound. Typically, sections are shipped in the fully extended condition to accommodate settlement in the borehole. However, sections can be ordered in any configuration, depending on the site specific requirements. The telescopic section is equipped with Snap Seal ends, thus allowing it to be installed similar to a standard piece of casing (section 4.3).

If the telescoping sections are equipped with settlement rings, then lower the sensor into the casing and record the initial readings for each settlement ring. Contact Geokon for more information on Settlement Monitoring Systems.

The moving joint of the section is sealed by two O-rings (one at either end). Each telescoping section contains four set-screws two on each side (Figure 5), which are individually sealed with O-rings. These screws are set in tracks which are blocked by a small web of ABS material. When sufficient force, >200lbs, is exerted on the casing (very small in a geotechnical setting), the material will break allowing the casing to compress (or extend). This design allows the telescopic section to bear the weight of the casing above it, and collapse under the force of ground settlement and/or rebound.

To prevent mis-tracking of the inclinometer probe as it passes through the telescoping section, the end of the grooves have a tapered "V-notch". This notch ensures that the wheels of the probe re-establish themselves in the correct track.

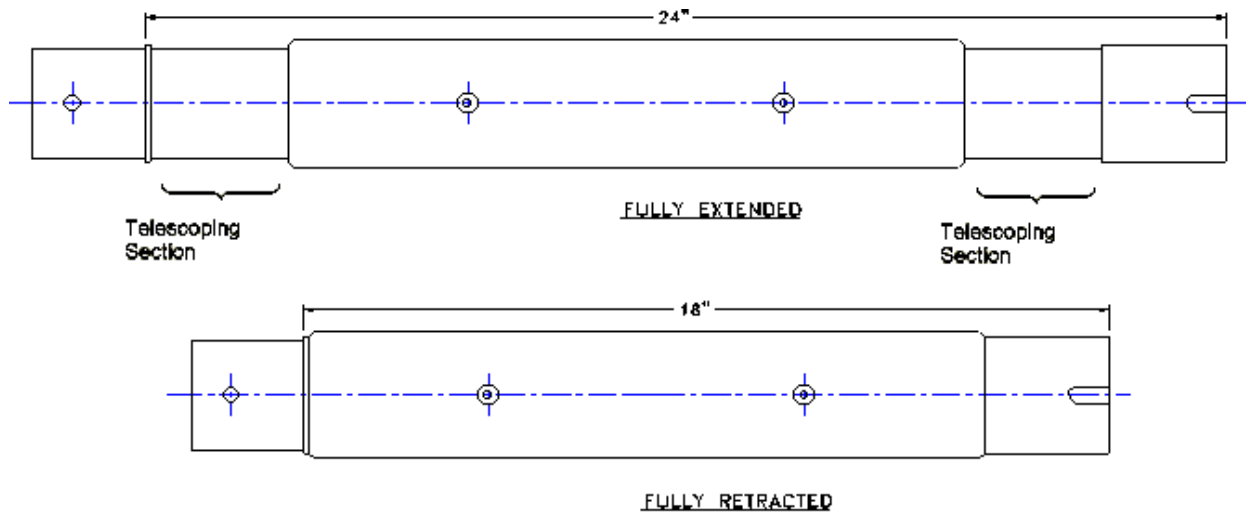

Figure 5 – Geokon Glue and Snap Telescoping Section

5. Installing Glue and Snap Casing

5.1 Installation Notes

Casing Storage

Casing should be stored horizontally and supported evenly so that it does not warp or bend. Whenever possible, casing should be stored in the shade since prolonged exposure to the heat of direct sunlight can cause deformation.

The Borehole

Drill the borehole as vertical as possible, preferably within 1 degree. Flush the borehole clean, and verify that the borehole is fully open to the bottom. Check the depth of the borehole before you begin installing the casing. Also consider that grout valves or external weights may require a deeper borehole.

Groove Alignment

It is important to have one set of grooves oriented down slope, in the direction of expected movement. If the direction cannot be determined, orient North/South. **Alignment must be maintained throughout the installation, to avoid introducing torsion to the casing, thereby causing spiraling of the grooves. Never push the casing from the top or twist the casing during installation.**

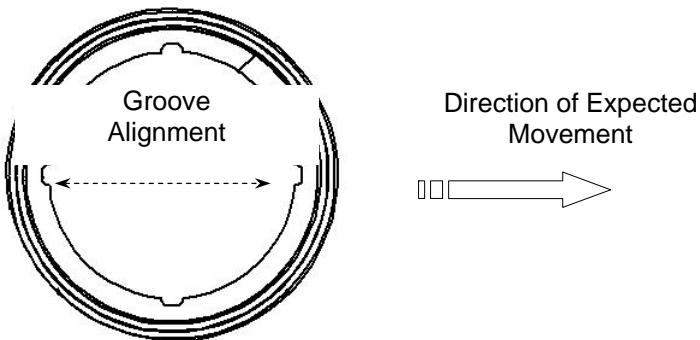

Figure 6 – Groove Alignment

5.2 Installation Methods

Using Pipe Clamps

This method involves using pipe clamps to hold the casing at the borehole collar while you add the next section of casing. Two pipe clamps are needed. In dry boreholes or in situations where down-hole problems seem likely, rig a safety line to provide extra security and a way to retrieve the casing if necessary.

- 1 Install an end cap on the first section of casing.
- 2 Attach one clamp to the top of the first section of casing. Lower the casing into the borehole until the clamp rests on the borehole collar.
- 3 Attach a second clamp to the top of the next section of pipe. Connect the two sections according to the instructions outlined in *section 4*. Remove the first clamp and lower the section into the borehole.

Repeat steps 2 and 3 until installation is complete. When to depth, verify the alignment of the grooves by running a dummy probe to the hole bottom. If the probe will not pass, jumps track, or returns in another set of grooves, pull the casing and rectify the problem.

In deep boreholes, it is advantageous to use a safety line to restrain the casing during installation. This can be used in conjunction with the casing clamps to lower the casing a controlled rate. Note that using the safety line by itself may induce spiraling due to the spiral lay of the rope, and is not recommended.

5.3 Casing Buoyancy

If the borehole is filled with water or mud, ballasting the casing with clean water can neutralize the casings' buoyancy. Exercise caution with this technique, as in dry boreholes, the differential pressure caused by the head of water may cause the casing to fail.

Casing also becomes buoyant during the process of grouting the borehole. The two following methods can be used to prevent the casing from floating out of the borehole during grouting:

- 1 Drill rods may be inserted inside the casing to hold the string from the bottom.
- 2 The bottom of the casing may be anchored in grout, then the balance of the borehole grouted.

Note

Applying a down-force to the top of the casing will likely distort the casing profile. Never use the drilling rig as a reaction force, or wedge the collar of the borehole. This will cause the casing to assume a large radius bend, making readings virtually useless.

In many cases, it is standard practice to attach a weight to the bottom of the casing to counteract the buoyancy effects of the casing. In situations where the casing is being inserted into a freshly grouted borehole, these buoyancy forces can be significantly large. Geokon cautions against using too large of a weight as it may fail the joint on the bottom cap or elsewhere in the casing.

5.4 Grouting

Properly mixed grout must be thin enough to pump, but thick enough to set in a reasonable amount of time. Ensure that the grout is free of lumps. If the mixture is too watery, it will shrink excessively, leaving the upper portion of the borehole un-grouted. Also, avoid the use of grouts that cure at high temperature since these may damage the casing.

Begin to tremie in grout as directed by the engineer. Grouting, via a high shear filtered grouting machine is recommended to avoid problems with lumps obstructing the tube.

Observe the water meniscus in the casing as an indication of casing collapse, or grout ingress (i.e. if the water in the casing rises, grout ingress can be assumed). Ensure that differential pressures are kept to a minimum, as the casing will collapse at 240 PSI differential.

Deeper boreholes will require a stage grouting procedure, with appropriate stages dependant on borehole water level, grout density, grout pump type, etc.

Note

Proper grouting of inclinometer casing is crucial to a successful inclinometer installation. The on-site engineer is required to have experience and can work with the drill crew on the proper mixture for the grout. Grout consistency is very important to ensure proper curing and to avoid separation of the solids and water. Grout must also have the proper viscosity which will enable it to be pumped easily.

In summary, grouting needs to be performed by experienced personnel, site conditions vary to the extent that each inclinometer installation is unique. Good judgment by on-site personnel and previous experience is the key to a successful installation.

6. Repairing Damaged Casing

Damaged Glue & Snap Casing can be repaired using Geokon repair couplings. Most of the time, casing becomes damaged near the top of the borehole due to movement of heavy equipment etc. In any case, the damaged portion of the casing needs to be removed.

1. Cut off the damaged portion of the casing using a hacksaw. Be sure to make this cut as square as possible. Remove all burrs.
2. Apply ABS 771 Cement to the inclinometer casing (Figure 7). The repair coupler will slide over top and the alignment tool will be used.

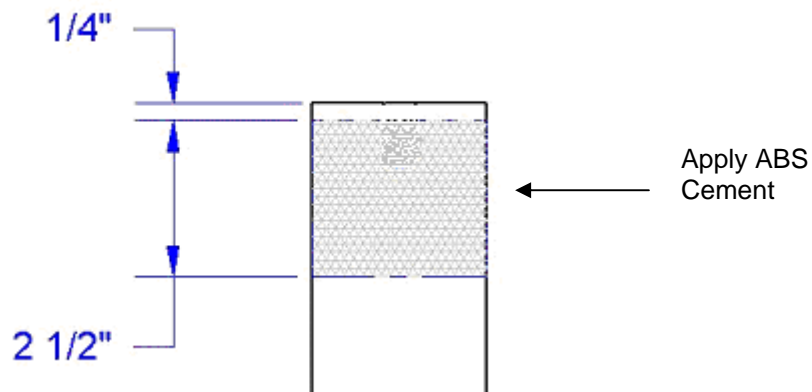

Figure 7 – Casing Preparation

3. Slide the Geokon repair coupling onto the casing and align the grooves using the Geokon Coupling Tool (Figure 8). Allow the cement to cure, according to the directions on the label.

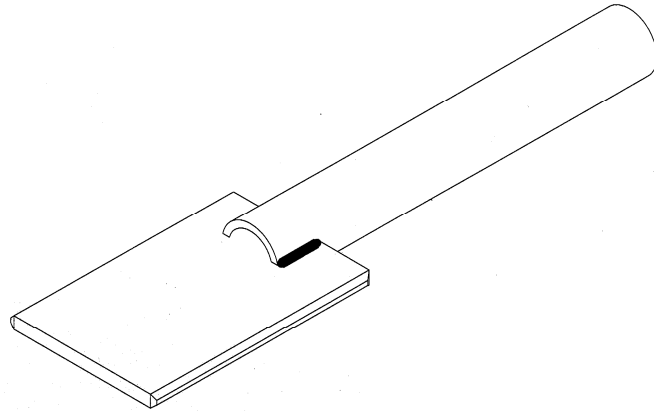

Figure 8 – Geokon Coupling Tool

4. Attach subsequent casing sections as described in section 4.3.

7. Installing Corrugated Settlement Sheath Pipe

Another option to using Telescopic Sections is the use of Corrugated Settlement Sheath Pipe. This allows the inclinometer casing to remain in a static position while the ground moves around it. Settlement can thus be observed at the collar of the borehole. For example, if the ground settles, the casing will be observed to extend farther out of the ground than previously.

Installation Method:

1. Insert a weight into the bottom of the sheath with the groove side down, leaving room for the installation of the end cap.
2. Slide 2 band clamps over the sheath and tighten so that the clamps squeeze the sheath into the grooves locking the weight into place.
3. Install the End Cap onto bottom of the sheath.
4. Seal with Denso tape and Duct tape.
5. Lower Corrugated Settlement Sheath Pipe into the borehole.

Note: Ballasting the pipe with clean water may be necessary to counter the buoyancy encountered with wet bore holes.

6. Install Inclinometer casing inside the Corrugated Settlement Sheath Pipe.
7. Eliminate any slack by pulling on it by hand (hold in place while performing step 8).
8. Fill the void between the sheath and borehole with grout, ensuring that no grout gets into the sheath or casing.
9. If Corrugated Settlement Sheath is equipped with settlement rings, then lower the sensor into the casing and record the initial readings of each Settlement Ring. Refer to the Geokon Manual "Settlement Monitoring System".

8. Protective Caps

A length of 4 inch galvanized steel pipe can be placed around the top of the casing and grouted into the ground. A lockable protective cap, as shown in Figure 9 can be threaded on the top of the steel pipe to protect the casing from vandalism.



Figure 9 – Protective Cap

When using a lockable protective cap it will be necessary to add a repair coupler to extend the top of the casing outside the cap so that the pulley assembly can be attached.



Figure 10 - Glue-Snap Casing Repair Coupler in place.

9. Snap Glue Inclinometer Casing Grout Adapter & Grout Casing Anchor

Suggested Installation Method

Prerequisites

- Suitable grout mix design – typically water-cement–bentonite to achieve suitable (low) strength, anti-wash, slow set, easily pumpable mix. Sand in the grout mix is not recommended as sand can prevent closing of the check valves during removal of the grout line. The pumped product should be completely lump-free, with no tendency to separate or clump.
- Suitable grout batching, mixing, and pumping equipment with surface hoses, water supply, gauges etc.
- Wrenches, chain clamps etc
- Sufficient ¾" Schedule 40 metal (steel, galvanized, aluminum etc) pipe in 10 foot sections and couplings to reach from the grouting adapter to the casing stickup. Teflon thread tape is recommended, particularly with aluminum pipe. Measure and number the pipes to permit accurate vertical control.

Installation

1. Ensure that the borehole is clear to the required depth.
2. Fill the borehole with water and check that the water stands – if the water won't stay, neither will the grout.
3. Fit the grouting adapter to the bottom of the casing, and install the casing per the standard instructions, typically adding clean water as needed to counteract buoyancy.
4. Connect the female quick connector to section number 1 of ¾" pipe using Teflon tape. Lower into the hole and continue adding pipe sections in number sequence until the quick connector engages. Check that the relative positions of the casing and pipe make sense.
5. Make a suitable surface hold-down for the grout pipe to prevent the grout pipe lifting off at the quick connect under pumping pressure. If the grouting adapter is not fitted with an inclinometer casing anchor, the casing will also require a surface hold-down.
6. Make connections from the ¾" grout pipe to the grout pump and circulate water to ensure that the quick connect is correctly engaged. Water should return at the collar, outside the casing. The water level in the casing should not rise or overflow.
7. Batch the grout and start pumping. Monitor the grout pressure, which should stay low.

8. When undiluted grout returns at the collar of the hole, release the grout pipe hold-down and remove the grout pipe from the casing.
9. Top up the casing interior with clean water and monitor for any rise in level or overflow, which would indicate ingress of grout.
10. Flush the grout pipe and female quick connect with clean water the female quick connect can be manually opened by pressing in the middle with a 1/4" wooden dowel or similar object.
11. If step 9 indicates ingress of grout, reinsert the grout pipe without the quick connect and circulate clean water