



*The World Leader in Vibrating Wire Technology*

48 Spencer Street  
Lebanon, NH 03766, USA  
Tel: 603•448•1562  
Fax: 603•448•3216  
E-mail: [geokon@geokon.com](mailto:geokon@geokon.com)  
<http://www.geokon.com>

*Instruction Manual*  
Model BGK-6850A  
**Three Dimensional  
Pendulum Readout**

No part of this instruction manual may be reproduced, by any means, without the written consent of Geokon, Inc.

The information contained herein is believed to be accurate and reliable. However, Geokon, Inc. assumes no responsibility for errors, omissions or misinterpretation. The information herein is subject to change without notification.

Copyright © 2010 by Geokon , Inc.  
(Doc REV A, 11/10)



## Warranty Statement

Geokon, Inc. warrants its products to be free of defects in materials and workmanship, under normal use and service for a period of 13 months from date of purchase. If the unit should malfunction, it must be returned to the factory for evaluation, freight prepaid. Upon examination by Geokon, if the unit is found to be defective, it will be repaired or replaced at no charge. However, the WARRANTY is VOID if the unit shows evidence of having been tampered with or shows evidence of being damaged as a result of excessive corrosion or current, heat, moisture or vibration, improper specification, misapplication, misuse or other operating conditions outside of Geokon's control. Components which wear or which are damaged by misuse are not warranted. This includes fuses and batteries.

Geokon manufactures scientific instruments whose misuse is potentially dangerous. The instruments are intended to be installed and used only by qualified personnel. There are no warranties except as stated herein. There are no other warranties, expressed or implied, including but not limited to the implied warranties of merchantability and of fitness for a particular purpose. Geokon, Inc. is not responsible for any damages or losses caused to other equipment, whether direct, indirect, incidental, special or consequential which the purchaser may experience as a result of the installation or use of the product. The buyer's sole remedy for any breach of this agreement by Geokon, Inc. or any breach of any warranty by Geokon, Inc. shall not exceed the purchase price paid by the purchaser to Geokon, Inc. for the unit or units, or equipment directly affected by such breach. Under no circumstances will Geokon reimburse the claimant for loss incurred in removing and/or reinstalling equipment.

Every precaution for accuracy has been taken in the preparation of manuals and/or software, however, Geokon, Inc. neither assumes responsibility for any omissions or errors that may appear nor assumes liability for any damages or losses that result from the use of the products in accordance with the information contained in the manual or software.



## TABLE of CONTENTS

|  |    |
|--|----|
| 1. Operating Principle.....  | 2  |
| 2. Technical Features.....   | 3  |
| 3. System Components.....  | 4  |
| 4. Installation.....   | 5  |
| 4.3.2.1 System Components.....   | 8  |
| Figure 9 Inverted Pendulum.....  | 9  |
| 4.3.2.2 The first requirement is a vertical hole of sufficient diameter to ensure <i>that the stainless</i> steel wire never<br>comes in contact with the sides of the hole..... | 9  |
| 4.3.2.3 The two part Grout Anchor is assembled and the stainless steel wire is attached to it by.....  | 9  |
| 4.3.2.4.....   | 9  |
| 4.3.2.5 When the grout has hardened the stainless steel table can be assembled according to the.....   | 11 |
| 4.3.2.6 Sit the tank on top of the table and pass the wire up through the slot between the two.....  | 11 |
| 4.3.2.7 Pour a little water (or antifreeze solution) into the tank until the float raises enough to.....   | 11 |
| 5. DATA ACQUISITION AND REMOTE MONITORING.....   | 13 |
| 5.1 RS 485 Communications.....   | 13 |
| 6. USING THE SUPPLIED SOFTWARE.....  | 16 |
| 7. TROUBLESHOOTING.....  | 17 |
| 8. TECHNICAL SPECIFICATION.....  | 18 |
| 10 GEOKON MODEL BGK-6850A PENDULUM OPERATION NOTES.....  | 19 |
| 11 PENDULUM CONFIGURATION.....   | 20 |
| Set Sensor Address.....  | 22 |
| Set Wire and Calibration Parameter.....  | 24 |
| Set Reference Setting.....   | 24 |
| Set Time.....  | 26 |
| MultiLogger Configuration.....   | 27 |
| 4-20mA Configuration.....  | 27 |
| RS-485 Configuration.....  | 28 |
| Error Codes.....   | 31 |
| Pendulum Commands.....   | 31 |
| CR800/CR1000 Programming Example.....  | 32 |



**MODEL BGK 6850A 3D PENDULUM READOUT**

## **1. Operating Principle**

The BGK6850A Three-Dimensional Pendulum Readout is designed for use with direct or inverted pendulums. It automatically measures horizontal deflections in two directions plus changes in vertical distance between the top suspension point of the wire and the readout location and is suitable for use in measuring the tilting of large structures such as dams, high-rise buildings, bridges, etc.

The BGK6850A 3-D pendulum readout, (see Figure1), uses three high-resolution linear array CCDs (charge coupled device) as the basic sensors. Three collimated light sources at 90 degrees to each other shine on three photo-sensitive CCD screens. When the shadow of the pendulum wire falls on the CCD sensors an automatically generated scan of the CCD pixels maps, records and stores digitally on the built-in computer the coordinates of the shadow.

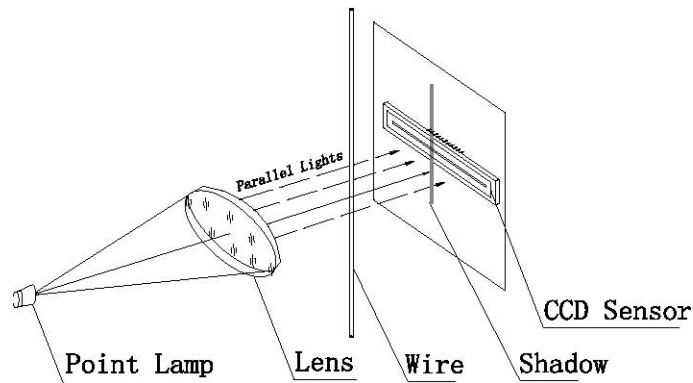

**Figure 1. The System of CCD imaging.**

This information is then converted to an analog signal that enables the position of the pendulum wire in the horizontal plane to be displayed locally in tenths of millimeter units on two LED panels mounted in the console. The vertical displacement is measured by a third pair of light source/CCD sensor system which monitors the position of a marker block clamped to the wire. The signal can be transmitted via 4-20mA output or RS485 output to a remote readout site. (See Figure 2).

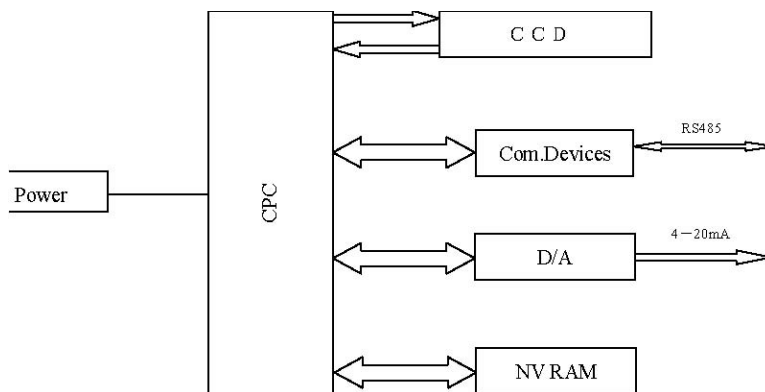

**Figure 2. Electrical Schematic.**

## **2. Technical Features**

- CCD photoelectric imaging, non-contact, horizontal measurement range 50mm x 100mm, and a vertical measurement range of 50mm with a resolution of 0.01mm.
- High Precision, no electrical drift, good long-term stability
- Strong ambient light resistance.
- Three built-in 4-digit LED visual display panels facilitate installation, debugging and manual observation of the three axis pendulum wire coordinates.
- Selectable sampling rate intervals from every 10 seconds to once per day.
- RS485 output coupled with an addressable network function makes it possible for several BGK6850A 3D pendulum readouts to be interconnected and addressed remotely and separately.
- 4-20mA output enables the BGK6850A pendulum readout to be compatible with all standard data acquisition and SCADA systems.
- Up to 1200 sets of measurement data can be stored.
- Power-Off protection with non-volatile storage ensures no data loss in the event of a power failure.
- A compact, sturdy and weatherproof cabinet along with sealed modular construction and moisture-proof circuitry ensure reliable performance in 95% humidity (non-condensing) environments.
- A slot in the cabinet enables it to be placed around the pendulum wire without dismantling the pendulum system.
- The built in power supply can work worldwide with voltages ranging from 85V to 265VAC.
- A Self-Diagnosing function can display a fault status on-site. In addition a remote diagnosis function allows the optics to be checked for cleanliness to determine if cleaning may be required.
- A Drip shield clamped to the pendulum wire prevents ambient light and water droplets from entering the CCD chamber.
- A Bracket is available to facilitate the mounting of the cabinet onto a vertical wall behind the pendulum wire. (Direct pendulum). Custom Brackets can be made to order.
- Alternatively the cabinet can be mounted on a table directly below the float tank, (Inverted Pendulum). Custom tables and float chambers can be made to order.

### 3. System Components

Figure 3 shows the components of the BKG6850A pendulum readout consisting of the upper and lower light shields, the cabinet with the square hole, slot, and a mounting plate on the bottom to mate with the optional Universal Mounting Bracket. Also shown are the three display panels and the input power and output connectors on the underside.

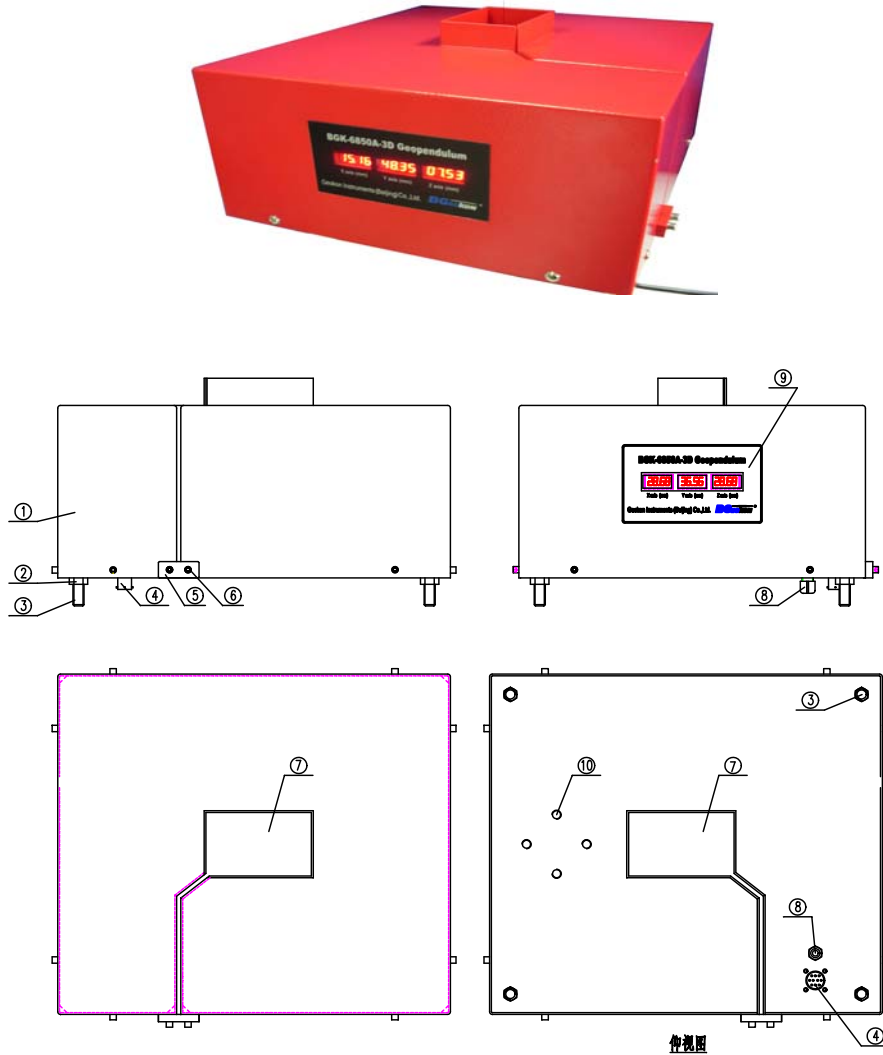
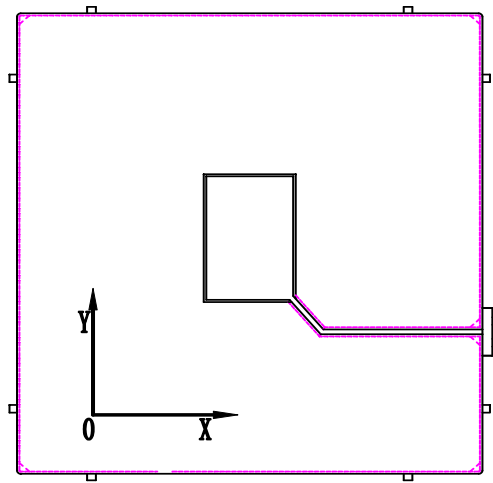

Figure 3. BKG-6850A three-dimensional pendulum system's external shape structure

## **4. Installation**

### **4.1 ORIENTATION AND PLACEMENT**

Figure 4 is a top view of the Cabinet showing the orientation of the X and Y axes. The arrows indicate the direction of wire motion with respect to the aperture which will result in a positive reading change. For dams the usual convention is to orient the front of the cabinet with the LED displays facing the downstream side so that the positive increase of the Y Axis reading corresponds to the wire moving from the front of the cabinet aperture to the back of the aperture.: whether this corresponds to an upstream or downstream movement of the dam wall depends on whether a direct pendulum or an inverted pendulum is in use. As the wire moves from the left side of the cabinet aperture to the right side the reading on the X axis will increase whether this represents a movement to the left bank or to the right bank depends again on what kind of pendulum is being dealt with.



**Figure 4. Dimensions and Orientation (Top View)**

### **4.2 INITIAL CHECKS**

First check the cabinet for signs of external damage. Now connect to the power supply, cover the top and bottom of the square hole so no light can enter. The display should read '**Err 4**' indicating that the shadow of the pendulum wire is absent. Now, insert a straight piece of wire 1.2mm diameter to simulate the pendulum wire into the rectangular space and a corresponding reading should show on the X and Y LED displays. When the needle or wire is centered the displays should read 50.00mm for the Y axis and 25mm for the X axis. (A 4-20mA reading should be about 12mA). Moving the needle back and forth should change the readings from 0 to 100mm.(Y) and 0 to 50mm (X).

To check the Z axis, clamp the conical Z block (supplied) to the wire with the flat face uppermost, and move the Z block up and down: the Z axis readings should change from 0 to 50mm.

### **4.3 MOUNTING BRACKETS**

#### **4.3.1 DIRECT PENDULUMS**

##### **4.3.1.1 Direct Pendulum Anchorage.**

The wire for the direct pendulum system is normally anchored at the top of a borehole or in the roof of the gallery directly above the drill hole.

Angle brackets with a special wire centralizer are used to do this.

If the wire is to be anchored to the floor at the top of the drill hole, two angle brackets are required and if at the ceiling over the hole just the one bracket with the centralizer is used.

The brackets are shown below in Figure 5

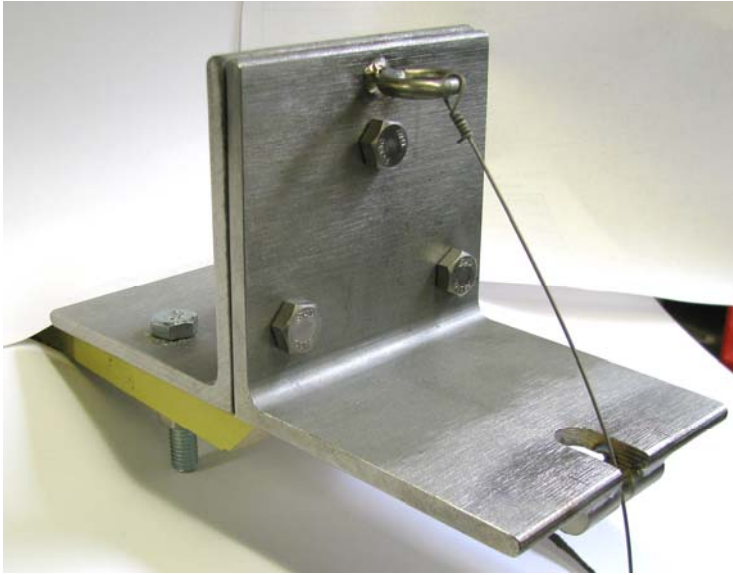

**Figure 5. Direct Pendulum suspension bracket.**

#### **4.3.1.2. Direct pendulums and intermediate stations – custom built bracket.**

A bracket is required to be bolted to a vertical wall next to the pendulum wire. The clearance between the rear wall and the pendulum wire needs to be at least 250mm (10inch), large enough so that there is space enough for the readout cabinet bearing in mind the orientation convention of section 4.1 and the dimensions shown in Figure 6 below.

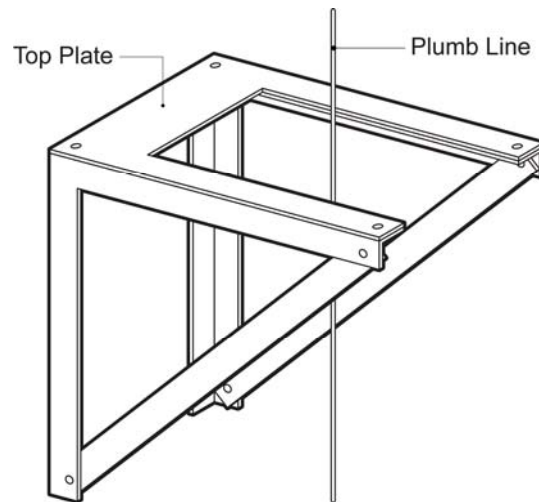

**Figure 6 Installation using custom brackets**

The brackets are best made locally, (but can be made by Geokon, if the necessary dimensions and orientation are provided).

A typical bracket might consist of two triangular pieces made from 45mm x 45mm angle iron that are connected together by one strut at the wall and a U shaped top plate. (See figure 6). Holes need to be drilled in the wall to match 4 slots cut in the bracket uprights. (Or there may be legs reaching to the floor). The positioning of the holes must be done very carefully to ensure that the pendulum wire will fall near the centerline of the aperture in the readout cabinet when it is mounted to the top of the bracket. To facilitate this it will be a good idea to make a template simulating the readout cabinet dimensions. This template (which also needs a slot cutting in it) can be used to position the holes in the bracket top plate for mounting the cabinet and also will help locate the mounting holes that need to be drilled in the wall so that the pendulum wire falls in the center of the aperture (or offset to one side as desired to accommodate the maximum movements anticipated). The mounting holes dimensions are shown in Figure 7

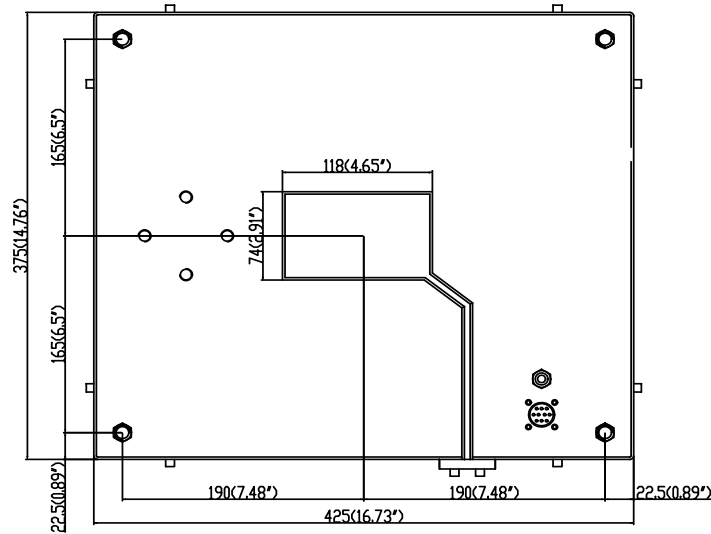

**Figure 7 View of the underside showing the mounting holes**

The mounting hole dimensions are 330mm x 380mm.  
The center of the aperture is at the center of the cabinet.

The holes drilled in the wall should be 12mm diameter into which the expansion bolts provided can be tightened. When the holes have been drilled and the expansion bolts anchored, slide the bracket assembly behind the pendulum wire then position the slots in the two bracket uprights around the anchor bolts. Bolt the plate to brackets using flat-head screws. Use a spirit level to level the plate then tighten the nuts onto the anchor bolts.

Screw the four cabinet mounting bolts (supplied) into the cabinet threaded holes. Tighten one nut to the cabinet and remove one of the other nuts from each bolt.

Before the cabinet is placed around the wire the Z block needs to be bolted to the pendulum wire at the correct height above the bracket. (See Figure 8) The correct height is 100mm above the base of the readout cabinet. To this number must be added the height of the mounting bolts holding the cabinet to the bracket. Install the Z block with its flat face uppermost. Use a Phillips head screwdriver to tighten the two screws holding the two halves of the Z block gripping the pendulum wire.

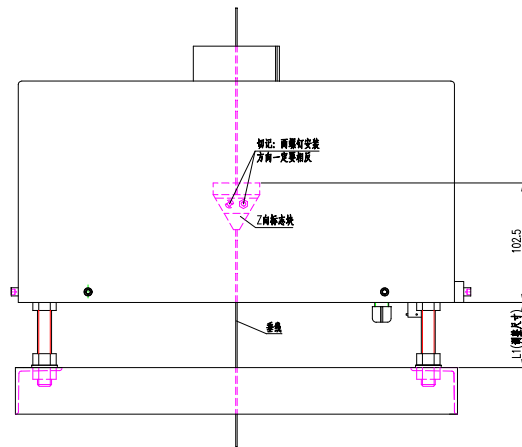

**Figure 8 Showing the position of the Z block**

The cabinet can now be placed around the pendulum wire above the Z block then lowered carefully (to avoid scratching the photosensors) until the four mounting bolts can be bolted to the bracket and held in place by the nuts removed previously.

**[ Installations can also be made using Velcro strips, instead of bolts, to hold the cabinet to the bracket. This is a simpler method and has the added advantage of allowing the cabinet to be repositioned easily]**

#### **4.3.1.3 Light Shields and Drip Shields**

In wet conditions a conical drip shield (available from Geokon) can now be attached to the pendulum wire to prevent water from dripping on the Z block and readout enclosure.

The pendulum readout may not work properly if the ambient light is too bright. Light shields if not supplied with the readout can be made on site out of 140 to 145mm dia PVC pipe with a slot cut in the pipe to allow the wire to pass through to the inside. The PVC pipe should be about 80 to 150mm long and should be painted black on the inside.

### **4.3.2 INVERTED PENDULUMS -TABLE MOUNTED -**

#### **4.3.2.1 System Components**

The BKG- 6850A Inverted Pendulum System is designed for use in dam embankments. The Inverted Pendulum is installed inside a vertical hole drilled or erected inside the embankment. At the base of this hole is anchored a stainless steel wire 1.3 to 1.5 mm diameter. This wire is kept vertical and taut by means of a float attached to the upper end of the wire. This float lies inside a donut shaped tank partially filled with water so that the center of the float always stays exactly vertically above the bottom anchorage point. Any lateral displacement of the upper part of the dam embankment relative to the lower part – either by sliding or tilting – causes the float and the top of the wire to move relative to the donut shaped tank and to the table support on which the tank and an electronic motion detector sits.

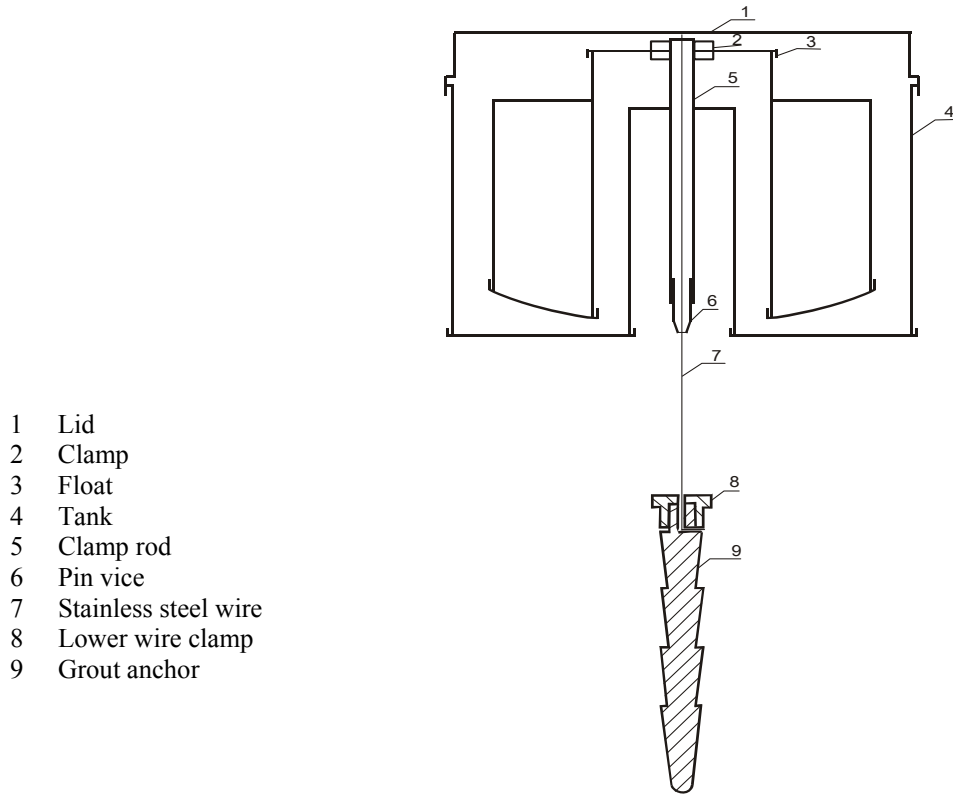

**Figure 9 Inverted Pendulum.**

**4.3.2.2** The first requirement is a vertical hole of sufficient diameter to ensure *that the stainless steel wire never comes in contact with the sides of the hole.*

**4.3.2.3** The two part Grout Anchor is assembled and the stainless steel wire is attached to it by means of the lower wire clamp. Details of the grout anchor and the method of attaching the wire are shown below in Figure 10.

**4.3.2.4** Calculate the amount of grout required to fill a space in the drillhole equivalent to the length of the pendulum anchor minus the approximate volume of the anchor. It is not a problem if the grout extends up over the anchor, just be sure there is a sufficient to cover the anchor.

Inject the grout into the bottom of the hole.

Suspend the anchor in the hole by lowering it to the bottom, through the grout, until it touches bottom and then pull it back up about one inch and suspend the system over the center of the drillhole at the surface.

This is based on the assumption that the drillhole is perfectly vertical. If it is known that this is not the case the anchor should be suspended at whatever point gives the most freespace in the expected direction of movement.

Always insure that there are no kinks in the wire at any time.

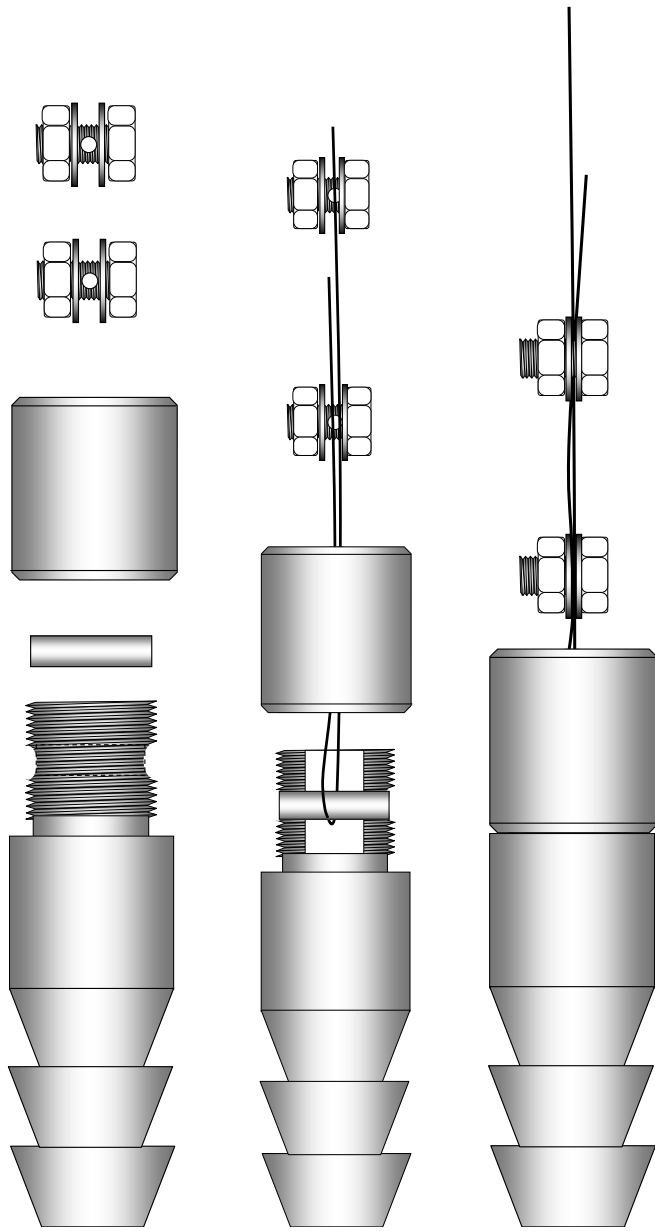

**Figure 10 Inverted Pendulum Grout Anchor and Lower Wire Clamp Details**

**4.3.2.5** When the grout has hardened the stainless steel table can be assembled according to the following instructions illustrated in Figure 12

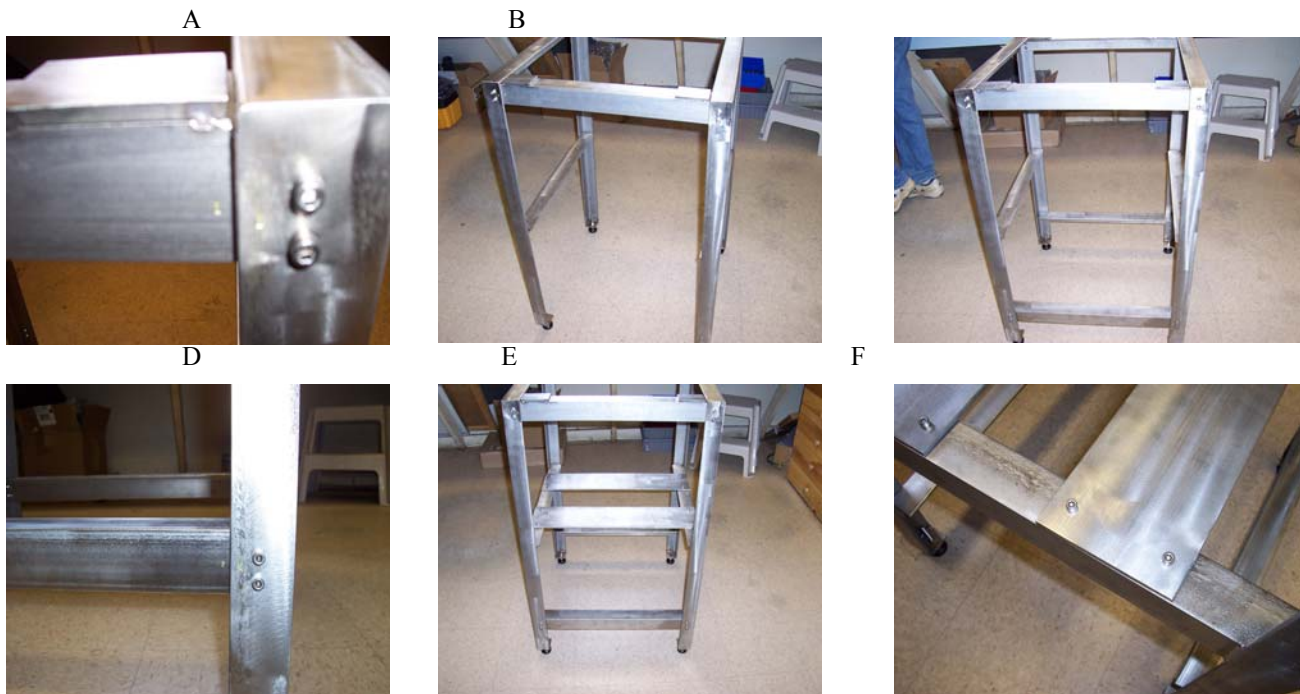

**Figure 11 Assembling the Inverted Pendulum Table.**

**A and B.** Connect the two side assemblies together at the top. Make sure that the pads are on top so that the tank can rest on them.

**C and D.** Connect the bottoms of the side assemblies together.

**E and F.** Connect the two shelf plates to the cross pieces on the side assemblies.

When the table has been assembled it is positioned over the top of the hole rotate it so that the slot between the two plates, on which the electronic enclosure will sit, is oriented in an upstream/downstream direction. With the aid of a spirit level, level the table using the adjustment screws on the feet.

**4.3.2.6** Sit the tank on top of the table and pass the wire up through the slot between the two plates and through the central hole in the tank. Clamp the clamp rod to the top of the float using the two big knurled nuts and pass the wire up through the clamp rod and out the top. Now lower the float into the tank. Push the end of the stainless steel wire through the hole in the upper wire clamp and out the hole at the side. Push the clamp down the wire until it is about 50mm away from the top of the clamp rod. Now tighten the upper wire clamp onto the wire. Cut off any excess wire.

**4.3.2.7** Pour a little water (or antifreeze solution) into the tank until the float raises enough to allow the upper clamp to seat inside the top of the clamp rod and exert some tension on the stainless steel wire. Check that the float is centralized within the tank. Slide the tank on top of the table until it is positioned centrally around the float, (move the table if necessary). Now add more water until the tension on the stainless steel wire is around 60 kilograms. (This happens when the float is submerged about 200mm). Now tighten the pin vise (located on the bottom of the clamp rod) to the stainless steel wire.

### 4.3.3 UNIVERSAL TYPE MOUNTING BRACKET

An alternative to the fixed bracket is the Universal Bracket the components of which are shown in figure 12 below

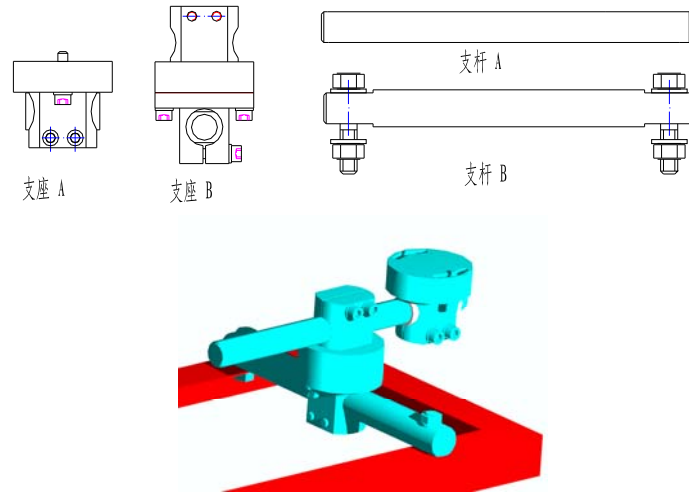

Figure 12 The Universal Bracket and Components

These components Bolt to a mounting bracket similar to that described in Section 4.3.1.2

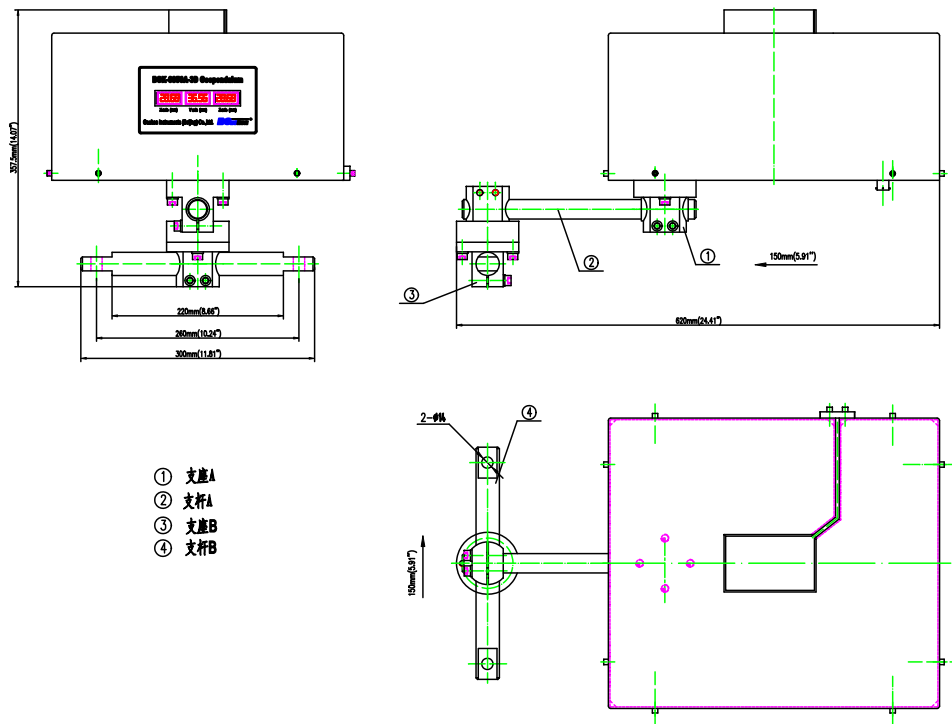
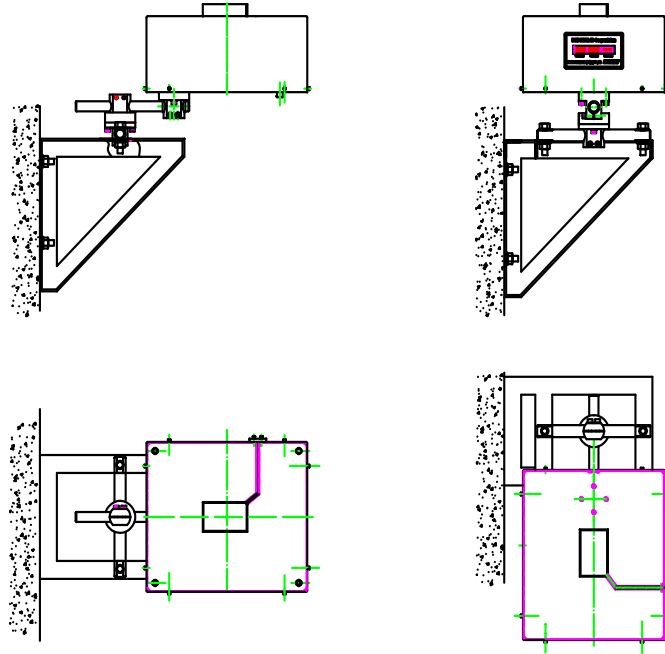

Figure 13 Universal Mounting Bracket

The bolt hole spacing on the arms of the mounting bracket needs to be 260mm and the clearance between the two arms of the mounting bracket must be at least 220mm to allow the crossbar to seat properly.

The maximum dimension of the universal bracket when fully extended is 620mm

The total height of the assembly is 357mm



**Figure 14 Universal Bracket mounted on a side wall**

## **5. DATA ACQUISITION AND REMOTE MONITORING**

In addition to providing on-site monitoring the BGK6850A Pendulum Readout also has an RS 485 digital interface and a 4-20mA analogue output.

### **5.1 RS 485 Communications.**

Every BGK6850A Pendulum Readout has a separate network address. Up to 32 BGK6850A Pendulum Readouts can be connected together through the RS 485 interface as shown in Figure 15

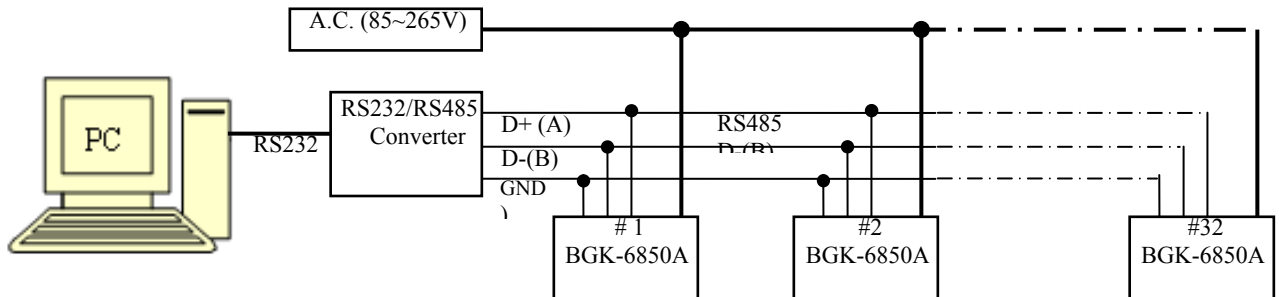

**Figure 15. The RS 485 Addressable Network**

**To prevent damage to the communications port, the RS-485 connection must be 3-wire and all devices, such as the cable shields and the 4-20mA SignalGND on the network must be connected to a common ground (GROUND)**

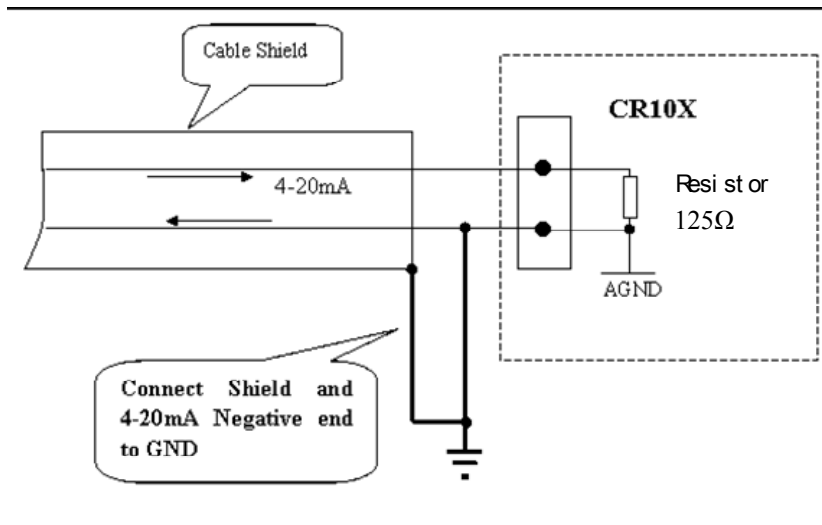

**Figure 16. 4-20MA signal connection.**

When using the RS 485 network the maximum distance to the farthest pendulum should not exceed 1200meters. And a 120 ohm resistance must be connected through a parallel connection to the RS 485 connector at the most remote pendulum to decrease signal reflectance. If the transmission distance exceeds 1200meters a fiber optic cable can be used. (With fiber optic cables there is no limit on the transmission distance and up to 99 pendulums can be connected into the network).

## 5.2 4-20mA Analogue Output

The BGK6850A Pendulum Readout provides a 4-20mA output which can be measured using a high precision (0.1%) digital ammeter such as the 20mAlevel of a 4.5 bit digital multimeter or any standard datalogger. If ammeters are used then two are required per pendulum – one for each axis X and Y.

The 4-20mA output can also be read using the BGK-Micro-40 readout unit (or other data logger) as shown in figure 17

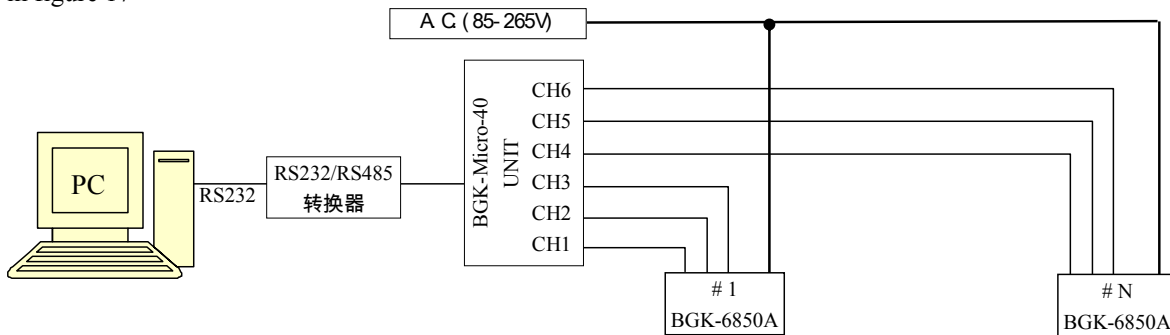

**Figure 17 using the BGK-Micro-40 measurement unit to measure the analog signal**

### 5.3 Wiring Diagrams

The Power connector is located on the base of the cabinet

| Power Cord<br>3-conductor | Label | Function |
|---------------------------|-------|----------|
| RED                       | L     | Line     |
| BLUE                      | N     | Neutral  |
| GREEN                     | GND   | Ground   |

**Table 1 Power Cord Connections**

Every Pendulum Readout ships with a RS485 and 4-20mA cable equipped with 10-pin Bendix connectors

| 10-pin socket (RS485 /<br>Analog Output) | <u>definition</u> | <u>description</u>   |
|--|-------------------|----------------------|
| A  | I <sub>x</sub>    | X-axis analog output |
| B  | GND               | X-axis ground        |
| C  | I <sub>y</sub>    | Y-axis analog output |
| D  | GND               | Y-axis ground        |
| E  | NC                | null                 |
| F  | A                 | RS485-T/R-           |
| G  | B                 | RS485-T/R+           |
| H  |                   | null                 |
| K  |                   | Z-axis analog output |
| J  |                   | Z-axis ground        |

**Table 2 RS485A connector**

If the user receives communications cables already made up they are defined as follows

| 10-pin plug (RS232 / Analog Output) | Conductor color | <u>Definition</u> | <u>Description</u>    |
|-------------------------------------|-----------------|-------------------|-----------------------|
| A                                   | RED             | I <sub>x</sub>    | X-axis analog output  |
| B                                   | RED'S BLACK     | GND               | X-axis ground         |
| C                                   | WHITE           | I <sub>y</sub>    | Y-axis analog output  |
| D                                   | WHITE'S BLACK   | GND               | Y-axis                |
| E                                   | SHIELD          | GND               | <u>grounding</u>      |
| F                                   | GREEN           |                   | RS 485 TD(A)          |
| G                                   | GREEN'S BLACK   |                   | RS 485 TD(B)          |
| H                                   |                 | NC                | null                  |
| K                                   | YELLOW          | I <sub>z</sub>    | Z- axis analog output |
| J                                   | YELLOW'S BLACK  | GND               | Z axis ground         |

**Table 3 4-20mA and RS485A signal wiring diagram**

### 5.3 Data Processing

After installation Initial values of X and Y and Z are obtained. These are X<sub>0</sub>, Y<sub>0</sub> and Z<sub>0</sub>  
 Movements of the pendulum wire as displayed on the readout cabinet in mm ΔX, ΔY and ΔZ are then derived from the equations

$$\Delta X = X_1 - X_0$$

$$\Delta Y = Y_1 - Y_0$$

And

$$\Delta Z = Z_1 - Z_0$$

Where X<sub>1</sub> Y<sub>1</sub> and Z<sub>1</sub> are subsequent readings on the X, Y and Z axes.

When using the 4-20mA output the actual displacements of the wire in mm is obtained by multiplying the each of the measured ΔX and ΔZ by the calibration factor **3.125mm/mA** and the measured ΔY by **6.25mm/mA**

## **6. USING THE SUPPLIED SOFTWARE**

Every Pendulum Readout is shipped with a copy of free test software. For detailed instructions on how to use the software see the software instruction manual. For details on how to use with Multilogger software see section 10.

## **7. TROUBLESHOOTING**

The BGK6850 Pendulum Readout requires no regular maintenance other than periodic checks to see that the optics are clean. Using a computer and the software supplied with the readout it is possible to initiate a 'grayscale scan' that looks at all the pixels of the CCD output and determines if the optics require cleaning.

If it is determined that cleaning is necessary then it can be done with a clean, soft cloth slightly moistened with water if necessary. **Do not use any organic solutions in the cleaning process.**

The BGK6850 Pendulum Readout also has a self-diagnosis feature: when a fault occurs the display will show a corresponding error code(s) by which the fault can be traced and corrected. The table on the next page describes the faults and the error codes displayed.

| Displayed Error Code or fault symptom               | Problem   | Solution   |
|---|---|--|
| Err2  | The ambient light is too bright   | Enhance the light shielding methods or use an additional light shield. |
| Err3  | The light is too weak   | Return to manufacturer for repairs                                     |
| Err4  | There is no shadow indicating that the pendulum wire has moved out of range.                            | Re-adjust the position of the readout.                                 |
| Err5  | A fault has occurred in the CCD image sensor  | Return to the manufacturer for repair.                                 |
| Err6  | There are too many shadows indicating that some debris or water drops may be blocking the optical paths | Clean away any debris or water that are found.                         |
| Displays are blank                                  | Power supply has failed   | Restore Power  |
| Displays are Ok but the communications have failed. | The Readout address may be incorrect<br>There is a fault in the communication line                      | Reset the address<br>Check the communication cable.                    |
| No analogue output                                  | A fault has occurred in the readout box analogue circuit  | Return to the manufacturer for repair                                  |

### **Error Codes and Troubleshooting Information**

If the fault still exists after performing the suggested remedy return the readout to the manufacturer. Sometimes Err2, Err4 and Err6 appear alternately on the display when the ambient light is too bright.

## **8. TECHNICAL SPECIFICATION**

|                       |   |
|-----------------------|---|
| Measuring Range       | 50mm x 100mm x 50mm   |
| Resolution            | 0.01mm  |
| Precision             | 0.1mm   |
| Electrical drift      | Zero  |
| Operating Temperature | -15°C to +60°C  |
| Relative Humidity     | 95%RH   |
| Sensor                | CCD   |
| Outputs               | On-site LED display, RS485 and 4-20mA port  |
| Sample Frequency      | Once/10 seconds to Once/day, programmable   |
| Data Storage capacity | 1200 readings on non-volatile RAM. Each reading has values of X, Y, Z, date and time. |
| Power Supply          | 85 to 265VAC, 50 to 60Hz, 10Watts   |
| Enclosure             | Weatherproof, painted steel (Red)   |
| Dimension             | 480 x 430 x x220mm high   |
| Weight                | 16kg  |
|                       |   |

## **9 LIST OF PARTS SUPPLIED WITH THE BGK6850 3D PENDULUM READOUT**

| <u>Name</u>                    | <u>Quantity</u> | <u>Remarks</u>  |
|--------------------------------|-----------------|---|
| BGK-6850A pendulum system      | 1 set           |   |
| Z direction block              | 1 set           | Each set: 2 semi-cone; M4x20 stainless steel pan head screws        |
| Fixed Bracket installing bolts | 4 set           | Each set: 1 M12x80 stainless steel screw; 3 M12 stainless steel nut |
| RS485/4-20mA cable             | 1               |   |
| Universal bracket              | 1 set           | Option  |
| Light Shields                  | 2               | Option  |
| Drip Shield                    | 1               | Option  |

**10 GEOKON MODEL BGK-6850A PENDULUM OPERATION NOTES**

**Overview These Notes were written for the 2-axis pendulum but can be extrapolated to the 3-axis**

This Sensor Application Note #16 will provide information to help integrate the Geokon Model 6850 Pendulum into a Campbell CR800 or CR1000 based monitoring system when configured using MultiLogger.

It will include wiring details as well as programming details to deploy this equipment.

The Model 6850 Pendulum includes an RS-485 (half-duplex) interface as well as dual 4-20mA outputs.

Wiring – below is the connector pinout for the Geopendulum. The connector is located on the underside of the unit next to the power cord gland.

| Pin   | Description          | Color (Pre-assembled) |
|-------|----------------------|-----------------------|
| A     | X-Axis 4-20mA Output | Red                   |
| B     | Ground               | Red's Black           |
| C     | Y-Axis 4-20mA Output | White                 |
| D     | Ground               | White's Black         |
| E     | No Connection        |                       |
| F     | RS-485-              | Green                 |
| G     | RS-485+              | Green's Black         |
| H,J,K | No Connection        |                       |

4-20mA Connection

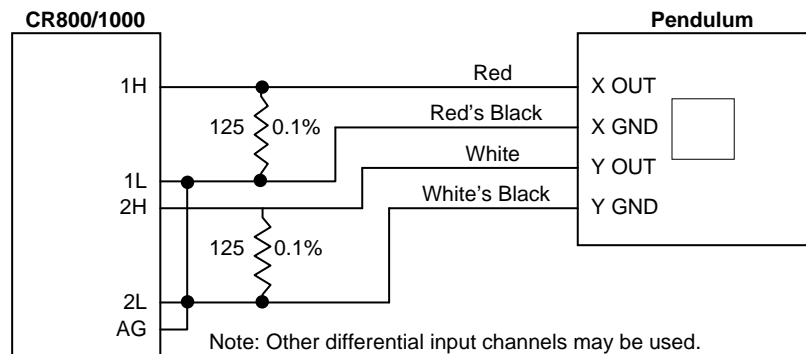

RS-485 Connection

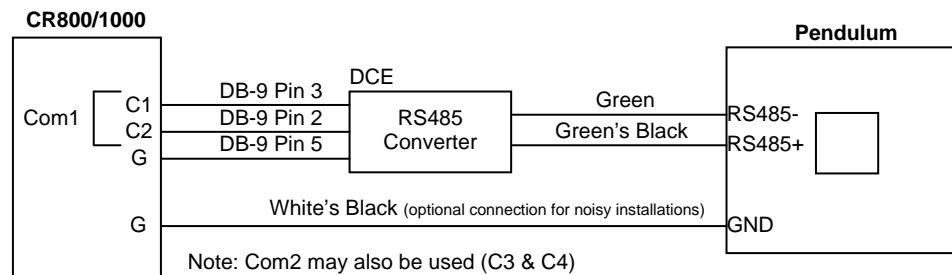

## 11 PENDULUM CONFIGURATION

The pendulum comes equipped with **CCDTest** software which is used for setting the pendulum parameters and checking the operation of the unit. Use the supplied installer to install the software. When starting the software you will see an interface as below.

Configure the **CommPort** which has the RS-485 adaptor attached, then click **OpenComm**.

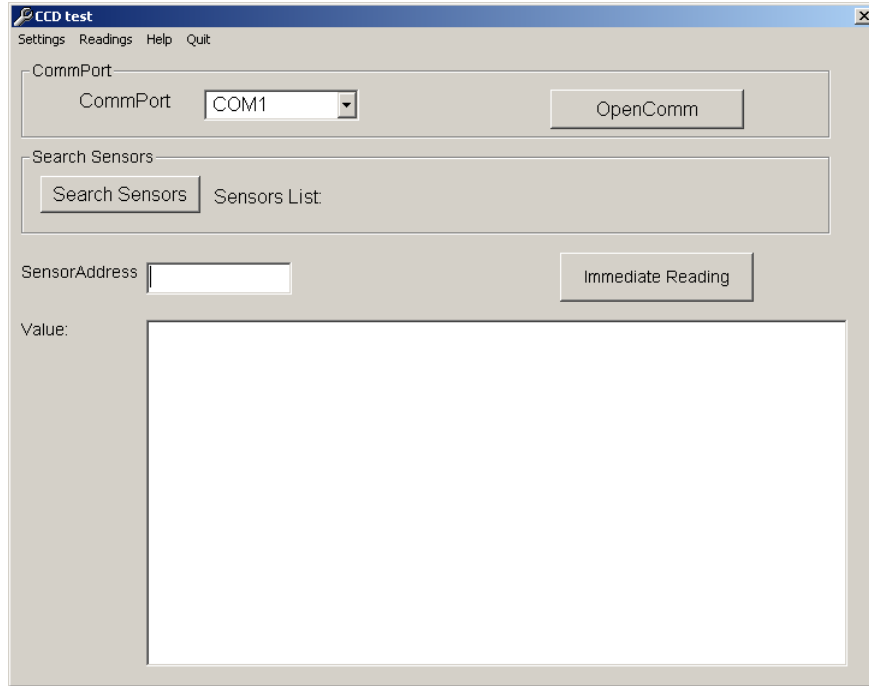

If you aren't sure of the pendulum's address then click the **Search Sensors** button to have the software try and locate them for you.

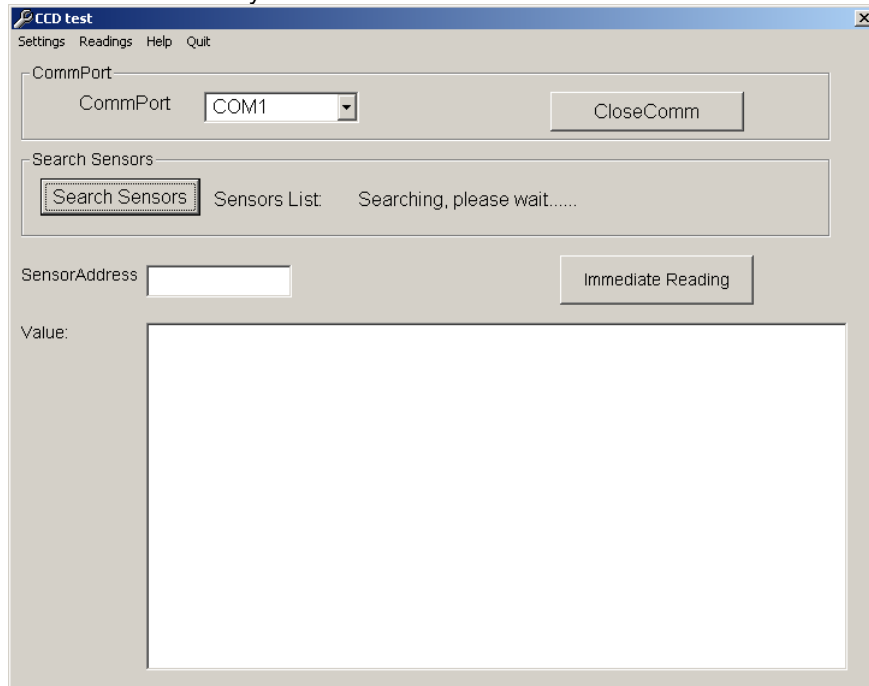

Sensors found will be shown in the **Sensors List**. Enter the Sensor Address you wish to communicate with in the **SensorAddress** edit, the example below shows address 15 was found and entered in the **SensorAddress** edit.

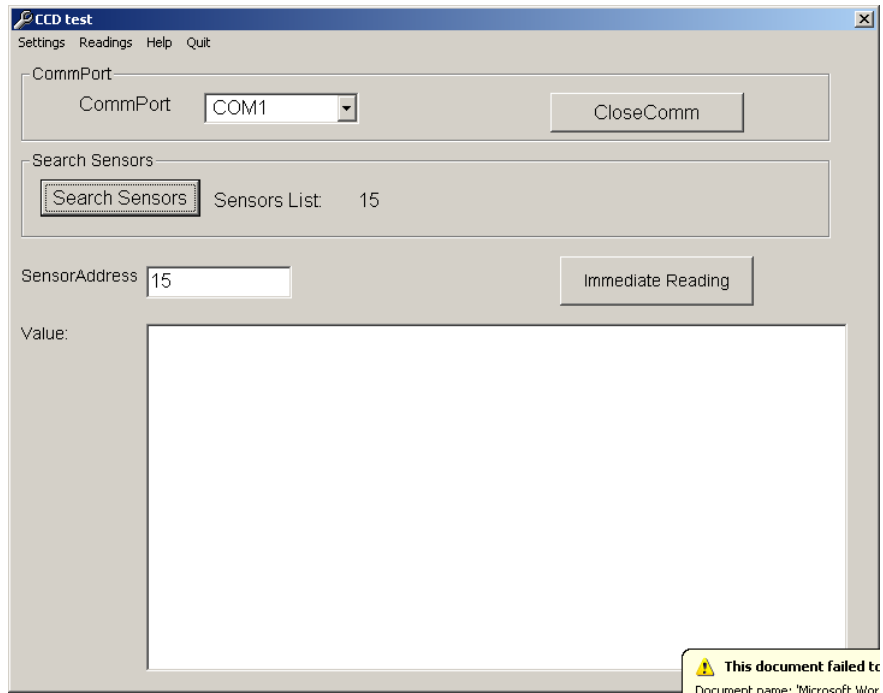

Click **Immediate Reading** to take measurements every 10 seconds from the attached pendulum.

The measurements will display in the Value edit with time stamp and X and Y values. Note any errors shown and troubleshoot if necessary. See the later section for an explanation of the error codes.

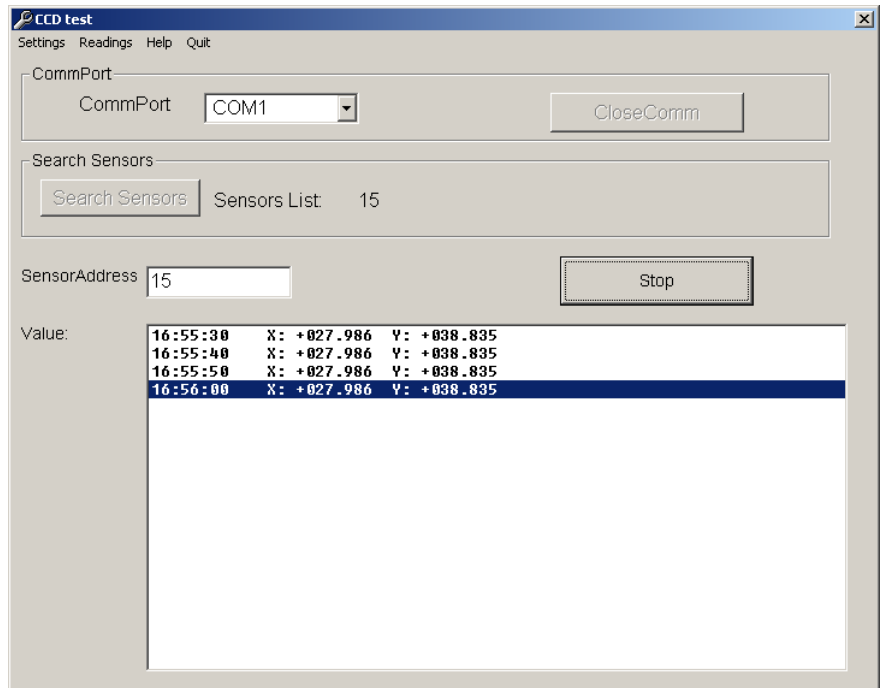

The CCDTest software provides several functions related to the configuration of the pendulum, in particular the setting of the Address, the wire configuration, the setting of the Reference values, the setting of the Clock and the orientation of the outputs. These options are available from the **Settings** menu in the upper left portion of the form.

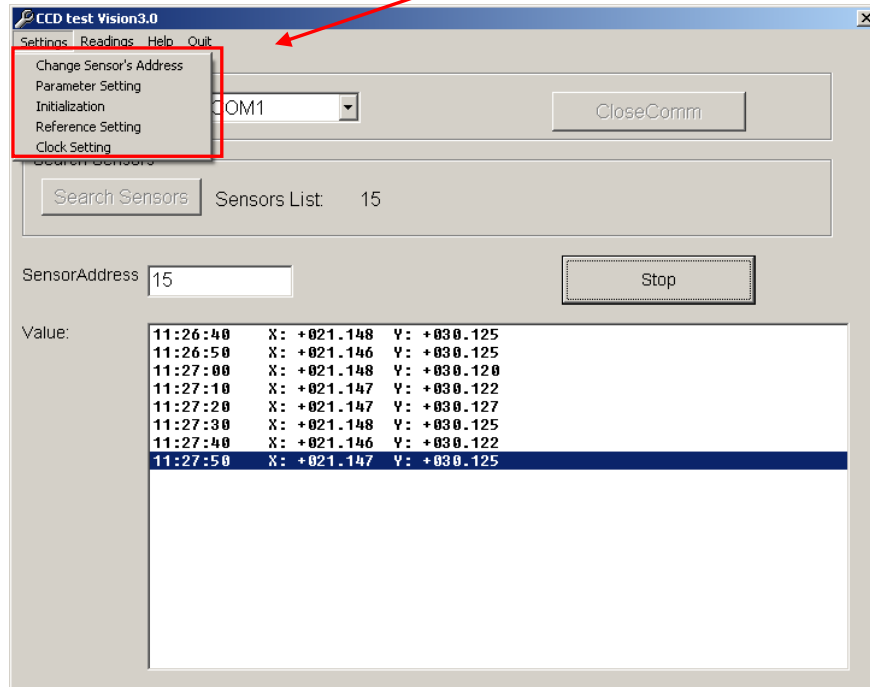

### Set Sensor Address

Use the **Change Sensor's Address** option from the menu – the Set Sensor's Address form will display.

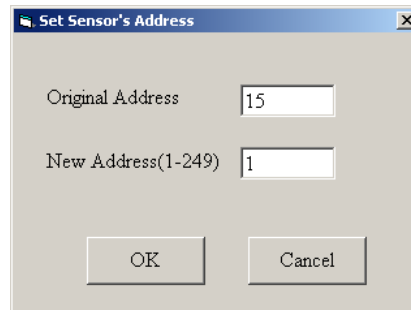

Enter the **Original Address** in the edit, followed by the **New Address**. Click **OK** when finished. The software will attempt to set the address and will show a status message. If it fails try again.

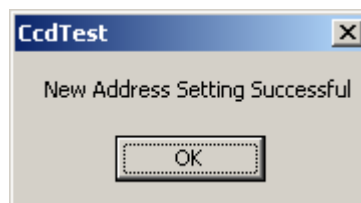

Once successful then click **OK** and then **Cancel** at the Set Sensor's Address form to return to the main form.  
 Note that once the address is changed you will need to update the **SensorAddress** edit with the new address. A **CommError** will display until you update the address, example shown below.

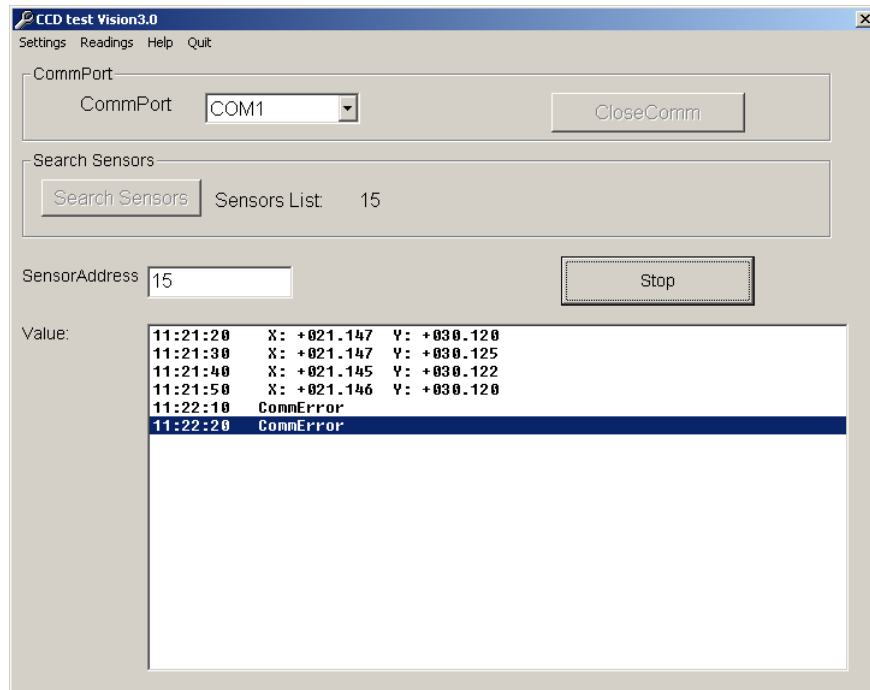

Once the **Sensor Address** is updated the readings should display properly again.

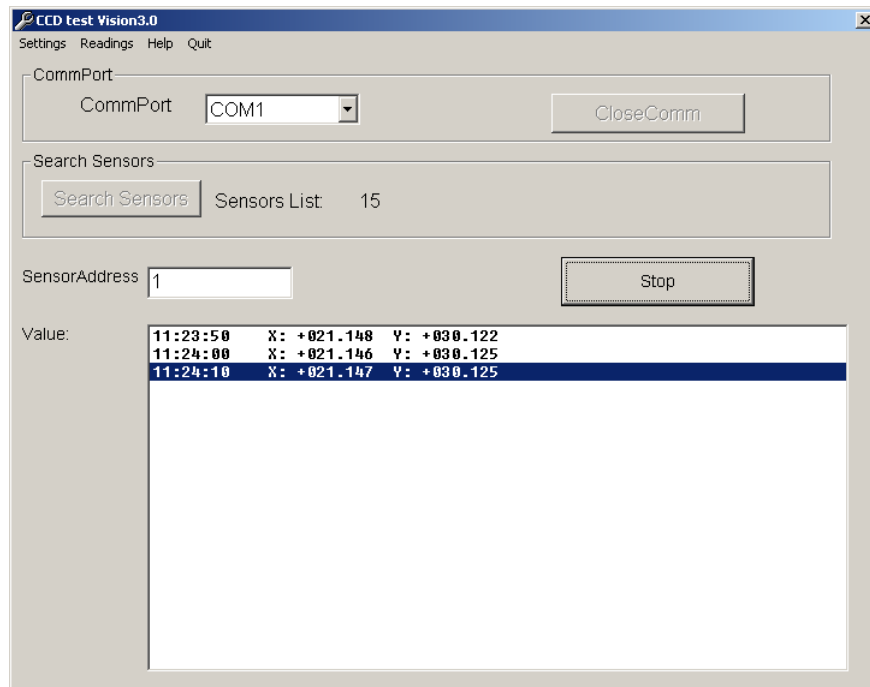

**Note: The Value display will clear after stopping and re-starting the Immediate Reading function.**

## Set Wire and Calibration Parameter

Use the **Parameter Setting** menu item to configure the wire diameter and error band.

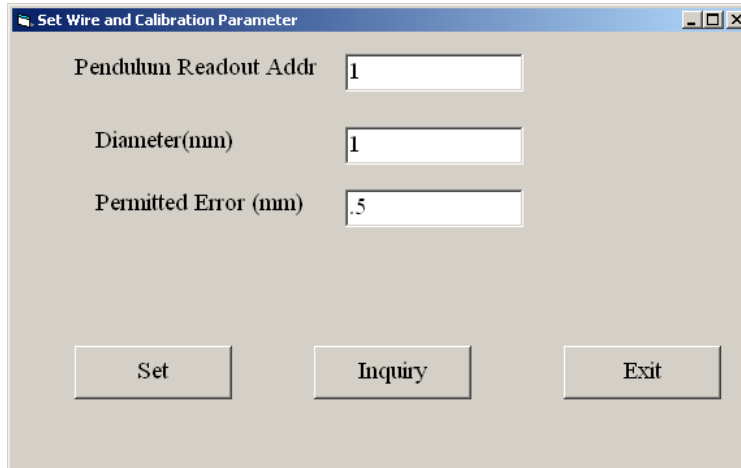

The screenshot shows a dialog box titled "Set Wire and Calibration Parameter". It has three input fields: "Pendulum Readout Addr" with the value "1", "Diameter(mm)" with the value "1", and "Permitted Error (mm)" with the value ".5". At the bottom of the dialog, there are three buttons: "Set", "Inquiry", and "Exit".

Configure the Sensor address to adjust, then enter the wire **Diameter** in millimeters and the **Permitted Error** in millimeters. The Permitted Error is usually entered as 0.5mm, shown above. Click **Set** to adjust the internal pendulum settings, you can also use the **Inquiry** button to check the current pendulum settings. Click **Exit** when finished to return to the main form.

## Set Reference Setting

The Reference feature allows adjusting the output of the unit for a given value. This is often used to maintain contiguous data when replacing units in service or moving the units for regular cleaning or other maintenance. Without the Reference feature then the values must be adjusted during post-processing to account for differences in measurements after moving or replacing a unit.

**Note: You must have the pendulum address entered in the SensorAddress edit on the main form for these options to work correctly!**

Use the **Reference Setting** menu item to display the Reference Setting form.

In the example shown the pendulum will be configured to show change in movement after installation. Enter 0.00 for the **X-Direction** and press **Set** to set this value as the X-axis Reference. The software should provide a message indicating successful Reference setting, along with the internal offset (the current absolute measurement) to adjust the output to achieve the desired Reference output.

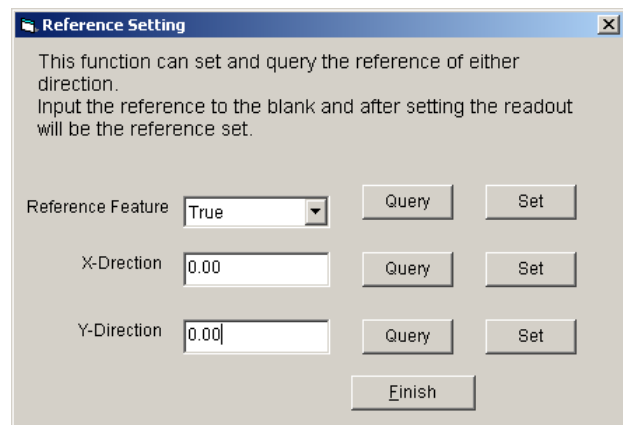

The screenshot shows a dialog box titled "Reference Setting". It contains a text area with the following text: "This function can set and query the reference of either direction. Input the reference to the blank and after setting the readout will be the reference set." Below the text area are three rows of controls: "Reference Feature" with a dropdown menu set to "True", "X-Direction" with a text box containing "0.00", and "Y-Direction" with a text box containing "0.00". Each row has "Query" and "Set" buttons. At the bottom of the dialog is an "Einish" button.

Enter 0.00 for the **Y-Direction** and press **Set**. AFTER pressing Set for both X and Y-Direction then configure True (default) as the Reference Feature and press **Set**. This will configure the unit to use the new X and Y-direction values as the starting values for the display and the 4-20mA output.

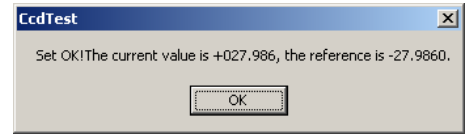

Click **Finish** when Reference Setting changes are complete. Once the Reference values are set you should see the display on the pendulum update to the new Reference values, close the form by clicking in the upper right corner.

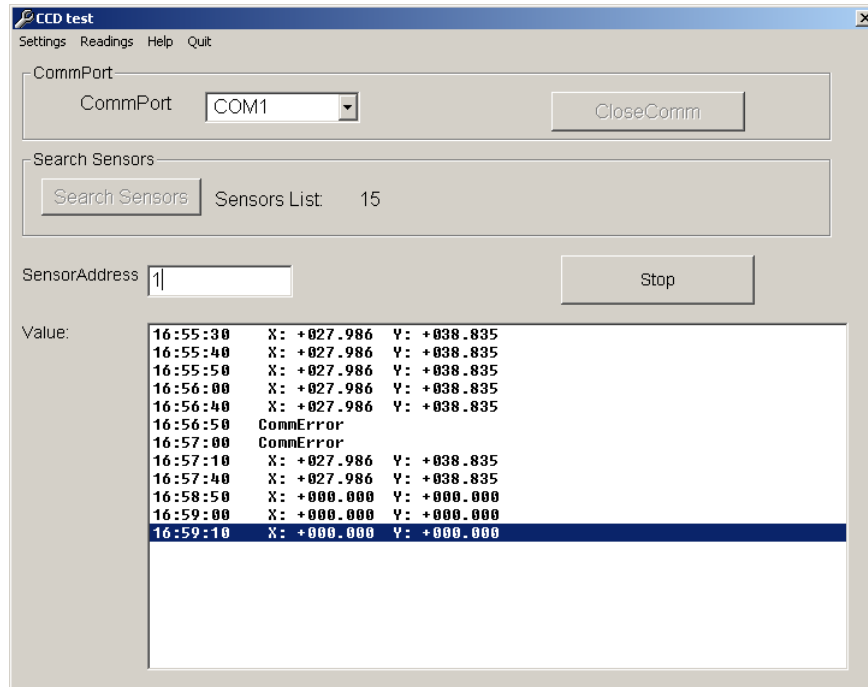

Note when returning to the main form the X and Y values should update to match the display, to show them as Referenced according to the values entered.

Consider this sequence as an example of how the References feature helps maintain contiguous data.

1. The values from the currently installed pendulum are 27.986 and 38.835 millimeters for X and Y respectively. The References feature is NOT being used so these are absolute values.
2. The unit is removed, cleaned and re-installed. The new readings are 25.456 and 31.894 for X and Y respectively.
3. Use the Reference Setting menu item to display the Reference Setting form. Enter 27.986 and 38.835 as the X and Y-direction References respectively. Set **Reference Feature** to True. The display will update to show the measurements last recorded prior to removing the unit. This provides for contiguous data without the need to apply post-processing offset corrections.

## Set Time

Use the menu item **Clock Setting** to display the Set Time form. Configure the pendulum address and press **Set** to match the internal pendulum clock to the PC clock.

This is useful when the pendulum is logging readings in its internal memory.

Click **Exit** to return to the main form.

Before using **Quit** to exit the CCDTest software be sure to Stop any automated readings and then use **CloseComm** to close the Comm port.

### Set Wire and Calibration Parameter

Use the menu item **Initialization** to swap the X and Y axis, this includes reversing the digital display and the 4-20mA outputs of the unit. This menu also provides for reversing the direction of each axis, for example if the X-axis is currently reading 35.78mm it will read 14.22mm if swapped. These features are useful where the installed orientation of the unit must match the direction of anticipated movement.

When selecting the menu item the Swap form will display. The default is False, however it may be changed to True by selecting from the drop-down menu and pressing **Set**. Press **Query** to view the current setting of the pendulum.

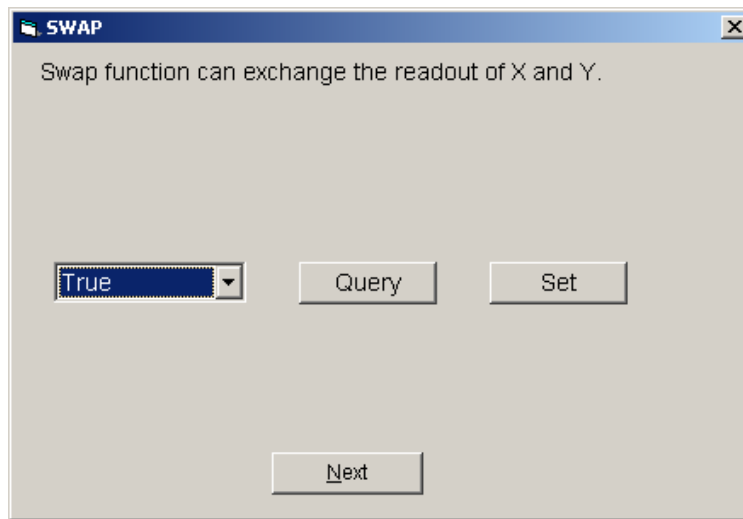
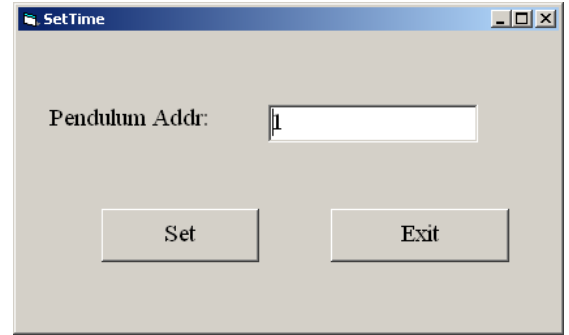

Click **Next** to continue to the Invert form. For each axis you may configure reversing the direction of movement. The default is **False**, use the drop-down for each axis to select **True** if needed. Press **Set** to update the pendulum with the setting, press **Query** to view the current settings.

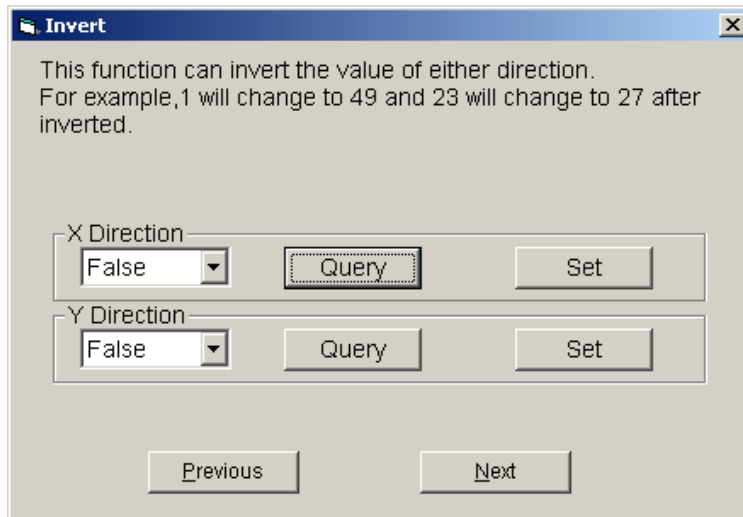

**Note: The Invert options will configure the axis as it is currently displayed. In other words if Swap is True then setting X Direction to True will invert the direction of what was originally the Y axis.**

When finished press **Next**, this will advance to Reference Setting form, see the previous section for detail on configuring these options. Press **Previous** to return to the Swap form.

### MultiLogger Configuration

The pendulum may be integrated to the Campbell MCU using the 4-20mA output or RS-485. RS-485 is recommended as it eliminates any analog measurement error from the readings.

### 4-20mA Configuration

Direct Connect Channels are used for configuring the Geopendulum measurements. Each channel corresponds to an X or Y-axis measurement – this provides for including the math to convert from mA to millimeters or other units.

Note the **Linear Coefficients** used to convert from current to millimeters.

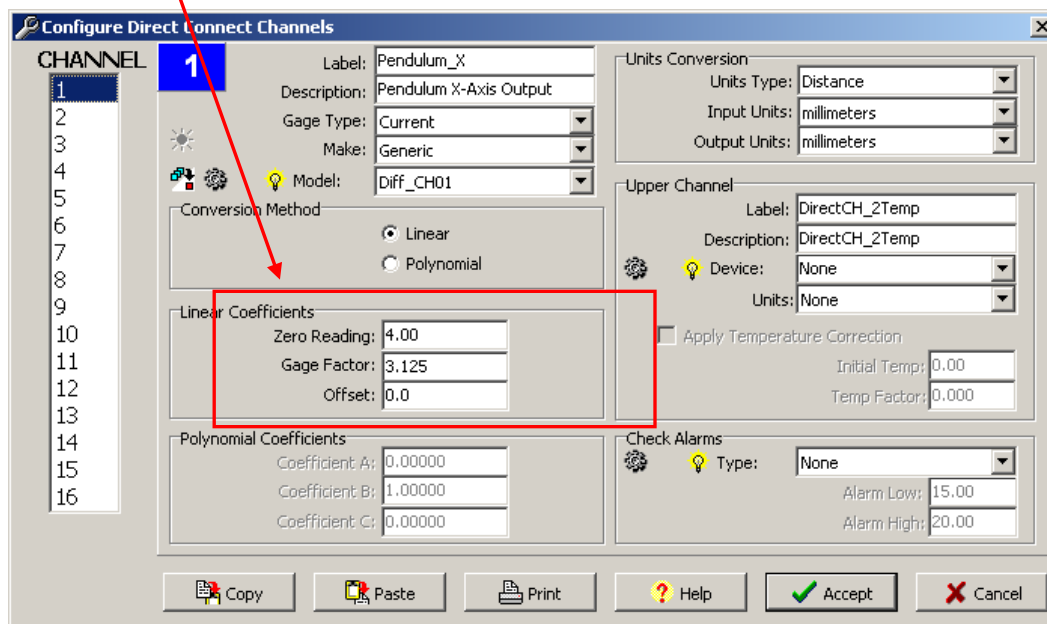

The Y-axis would be configured as follows:

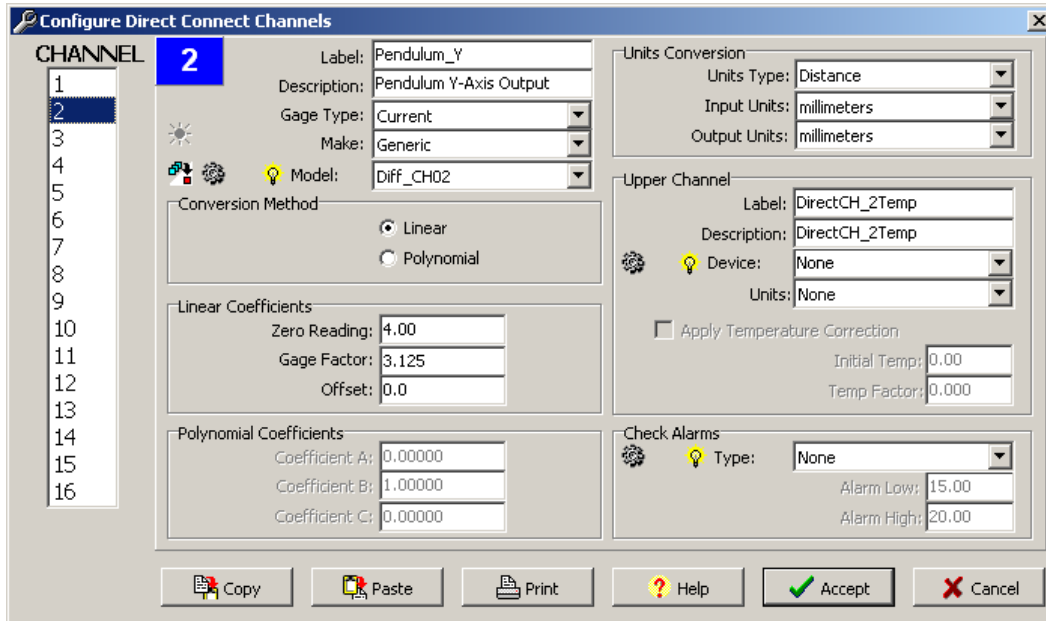

### **RS-485 Configuration**

**Note: Geopendulum RS-485 support is only provided for the CR800 and CR1000 control modules. The gage types referenced following are found in MultiLogger version 4.2 or higher. Contact your software vendor or Canary Systems directly to obtain the current version of software.**

Generally the **Direct Connect Channels** are used for configuring the Geopendulum measurements. There are 2 methods of configuring them, dependent on whether the resultant values must be converted to other units or Alarms must be configured on each measurement.

The output units of the Geopendulum are **millimeters**.

Shown below is a typical channel configuration to read the X and Y-axis outputs of a pendulum connected to Com1 on the control module (Control Ports C1 & C2 used for communications) at address 01. Addresses 1-16 are supported – contact Canary Systems if your application has more than 16 pendulums per network.

Note the availability of gage types for COM1 (Control Ports C1 & C2) and COM2 (Control Ports C3 & C4). The CR800 has 2 COM ports, the CR1000 has 4. Contact Canary Systems if your application requires the use of COM3 (Control Ports C5 & C6) or COM4 (Control Ports C7 & C8) on the CR1000.

Note that this configuration allows converting the X-axis values using the Conversion Method and/or the Units Conversion, as well as configuration of alarms using the Check Alarms options. You will not be able to make similar adjustments, nor utilize the Check Alarms for the matching Y-axis value.

**Configure Direct Connect Channels**

**CHANNEL 1**

1  
2  
3  
4  
5  
6  
7  
8  
9  
10  
11  
12  
13  
14  
15  
16

Label: Pendulum\_X  
 Description: Pendulum X-Axis Output  
 Gage Type: Pendulum  
 Make: Geokon  
 Model: 6850\_Com1\_01X

Conversion Method  
 Linear  
 Polynomial

Linear Coefficients  
 Zero Reading: 0.0  
 Gage Factor: 1.0000  
 Offset: 0.0

Polynomial Coefficients  
 Coefficient A: 0.00000  
 Coefficient B: 1.00000  
 Coefficient C: 0.00000

Units Conversion  
 Units Type: Distance  
 Input Units: millimeters  
 Output Units: millimeters

Upper Channel  
 Label: Pendulum\_Y  
 Description: Pendulum Y-Axis Output  
 Device: 6850\_Y  
 Units: millimeters

Apply Temperature Correction  
 Initial Temp: 0.00  
 Temp Factor: 0.000

Check Alarms  
 Type: None  
 Alarm Low: 0.00  
 Alarm High: 0.00

Copy Paste Print Help Accept Cancel

If your application requires conversions and/or **Check Alarms** settings then you will need to configure the Y-axis as a separate Channel. For example, Channel 1 would be configured as follows:

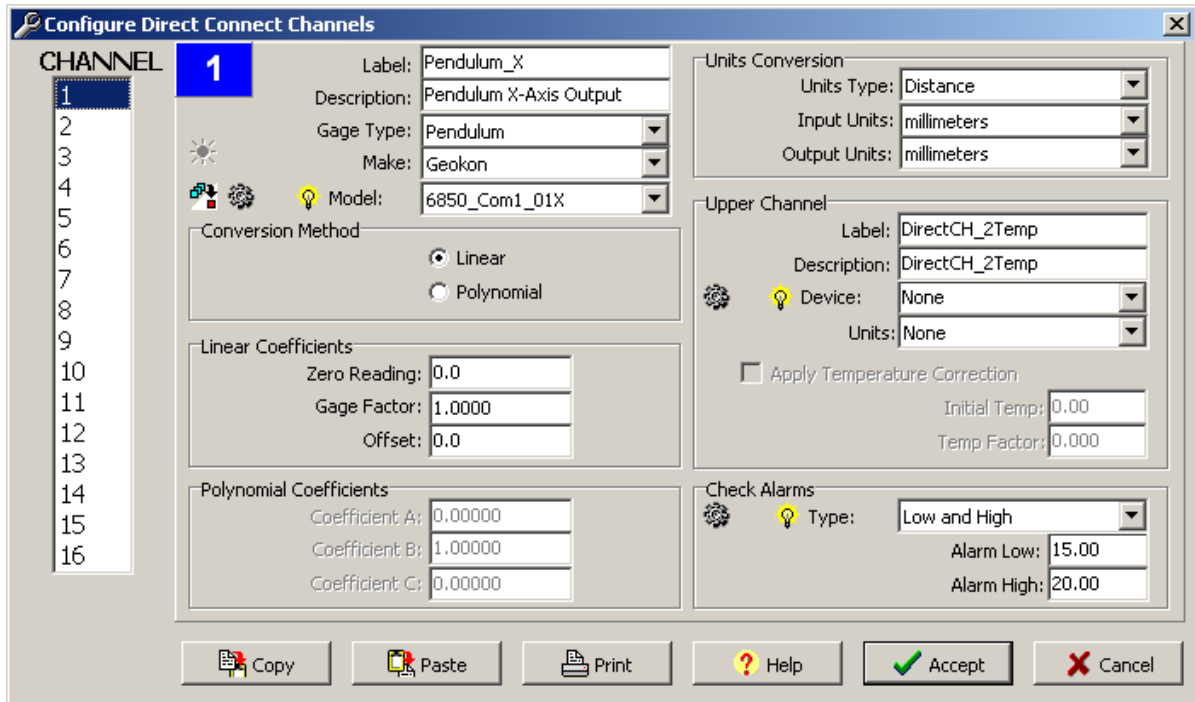

Channel 2 to support the Y-axis measurement would be configured as follows:

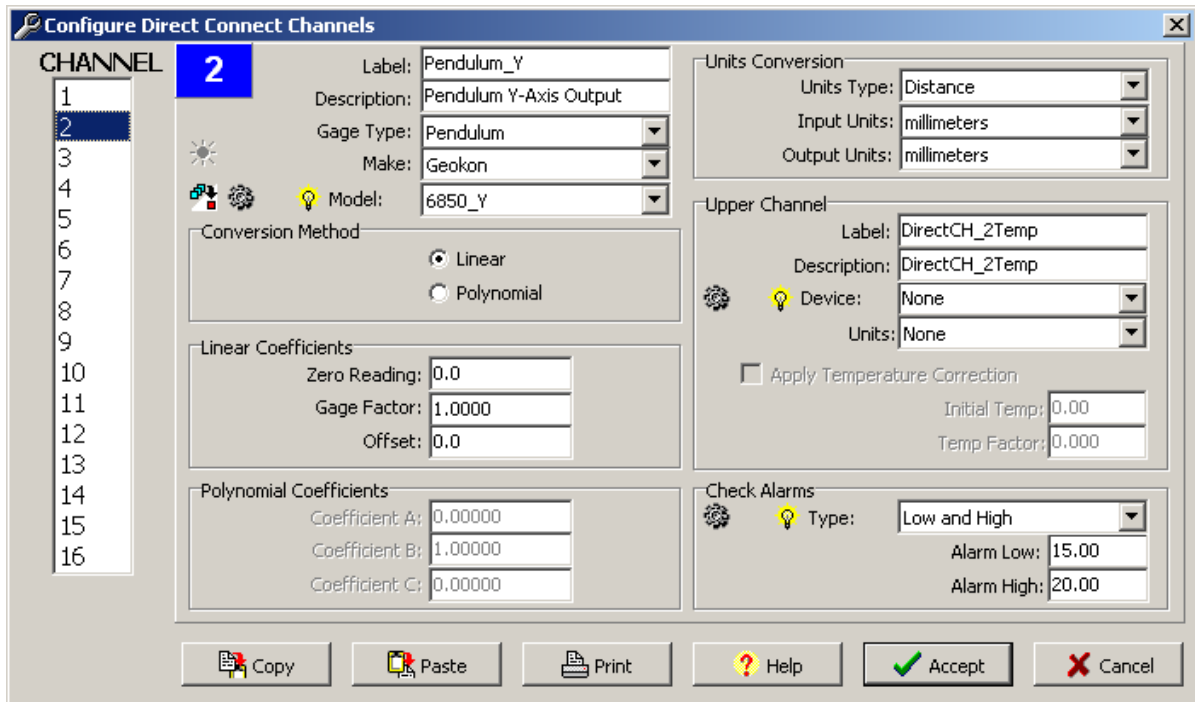

This configuration technique limits the number of pendulums that can be configured to 8.

## Error Codes

The Geopendulum has several error codes which indicate problems with the installation or the unit. These codes will be shown on the pendulum display and have equivalent values when automating the systems using MultiLogger. Please consult the Model 6850 Geopendulum Instruction manual for additional troubleshooting information.

| Code       | MultiLogger Code | Description   |
|------------|------------------|---|
| Err2       | -99992           | Ambient light is too bright.  |
| Err3       | -99993           | Projected light is too weak.  |
| Err4       | -99994           | Wire is out of range.   |
| Err5       | -99995           | Fault has occurred in CCD element.  |
| Err6       | -99996           | Shadows interfering with measurement – usually due to moisture or debris in the light path. |
| No Display | -99999           | Power loss to the unit or communication breakdown.  |

## Pendulum Commands

Terminal emulation programs may be programmed with the pendulum commands to help with troubleshooting and configuration of the units. Below are typical commands and responses. Communication parameters are **9600 bps, 8 data bits, 1 stop bit, no parity bit**. The baud rate of the pendulum is fixed at 9600 bps.

All commands are prefaced with a colon, “:”, followed by the address of the unit in hexadecimal notation, the command and any parameters and then terminated with “FF” <CR> <LF>. Responses include a two-byte signature (“gg”).

| Command   | Command                         | Response                                     |
|---|---------------------------------|--|
| Set Address, where;<br>aa = current address (01-FF)<br>bb = new address (01-FF)   | :aa02bbFF                       | :aa02bbFB                                    |
| Get X & Y Axis readings, where;<br>aa = address<br>s = sign (+/-)<br>xxx.xxx = x-axis<br>yyy.yyy = y-axis<br>gg = signature   | :aa2101FF                       | :aa2101sxxx.xxxsyyy.yyy gg                   |
| Set X-axis Parameters, where;<br>aa = address<br>ww = wire diameter in mm (2 digits no decimal, e.g. 1.0 mm = 10)<br>ee = error in mm (2 digits no decimal, e.g. 0.5 mm = 05) | :aa67wwee010000FF               | :aa67wwee010000gg                            |
| Set Y-axis Parameters (see above)   | :aa69wwee010000FF               | :aa69wwee010000gg                            |
| Query Reference Setting, where;<br>aa = address   | :aa76FF                         | :aa76rrgg                                    |
| Set Reference False   | :aa7500FF                       | :aa7500gg                                    |
| Set Reference True  | :aa7501FF                       | :aa7501gg                                    |
| Set X-Axis Reference, where;<br>aa = address<br>s = sign (+/-)<br>xxx.xxx = x-axis reference value (entered as an offset)   | :aa71Sxxx.xxxFF                 | :aa71Sxxx.xxxgg                              |
| Set Y-Axis Reference, where;<br>aa = address<br>s = sign (+/-)<br>yyy.yyy = y-axis reference value (entered as an offset)   | :aa73Syyy.yyyFF                 | :aa73Syyy.yyygg                              |
| Read/Set clock, where;<br>aa = address<br>yy = year<br>mm = month<br>dd = day<br>hh = hour<br>mm = minute<br>ss = second  | :aa04FF<br>:aa03yyymmddhhmmssFF | :aa04yyymmddhhmmssgg<br>:aa03yyymmddhhmmssgg |

**CR800/CR1000 Programming Example**  
**(gt\_6850\_com1\_01x.cr1 instruction file)**

```
'Read the X and Y output of a Geokon Geopendulum connected
to COM1 (C1 & C2) at Address 01
'Open our port
SerialOpen (Com1,9600,0,1000,255)

'Clear our counter
ScratchLoc(1) = 0

'Loop 5 times to get measurement
Do
  'Make sure buffer is clear
  SerialFlush(Com1)

  'Send Reading command
  SerialOut (Com1,":012101FF"+CHR(13)+CHR(10)," ",0,0)

  'Receive response with .25 second timeout
  SerialIn(sInBuf,Com1,25," ",30)

  'Check for enough characters
  if Len(sInBuf) >= 23 then
    'Split out response values
    Splitstr(ScratchLoc(2),sInBuf," ",3,0)

    'Check for error codes
    if ScratchLoc(3) = 2000000 or ScratchLoc(4) = 2000000 then
      ScratchLoc(3) = -99992
      ScratchLoc(4) = -99992
    endif
    'Check for error code
    if ScratchLoc(3) = 3000000 or ScratchLoc(4) = 3000000 then
      ScratchLoc(3) = -99993
      ScratchLoc(4) = -99993
    endif
    'Check for error code
    if ScratchLoc(3) = 4000000 or ScratchLoc(4) = 4000000 then
      ScratchLoc(3) = -99994
      ScratchLoc(4) = -99994
    endif
    'Check for error code
    if ScratchLoc(3) = 5000000 or ScratchLoc(4) = 5000000 then
      ScratchLoc(3) = -99995
      ScratchLoc(4) = -99995
    endif
    'Check for error code
    if ScratchLoc(3) = 6000000 or ScratchLoc(4) = 6000000 then
      ScratchLoc(3) = -99996
      ScratchLoc(4) = -99996
    endif

  'No valid response
  Else
    ScratchLoc(3) = -99999
    ScratchLoc(4) = -99999
  EndIf

  'Short delay before trying again or exiting
  Delay(0,250,mSec)

  'Increment our counter
  ScratchLoc(1) = ScratchLoc(1) + 1

Loop Until (ScratchLoc(1) >= 5) OR (ScratchLoc(3) > -99990)

'Copy our reading whatever it is (ScratchLoc(4) holds Y-Axis value)
mlReading = ScratchLoc(3)

'Close our serial port
SerialClose (Com1)
```