Model 1300

A-9 Retrievable Extensometer

Instruction Manual



WARRANTY STATEMENT

GEOKON warrants its products to be free of defects in materials and workmanship, under normal use and service for a period of 13 months from date of purchase. If the unit should malfunction, it must be returned to the factory for evaluation, freight prepaid. Upon examination by GEOKON, if the unit is found to be defective, it will be repaired or replaced at no charge. However, the **WARRANTY IS VOID** if the unit shows evidence of having been tampered with or shows evidence of being damaged as a result of excessive corrosion or current, heat, moisture or vibration, improper specification, misapplication, misuse or other operating conditions outside of GEOKON's control. Components that wear or are damaged by misuse are not warranted. This includes fuses and batteries.

GEOKON manufactures scientific instruments whose misuse is potentially dangerous. The instruments are intended to be installed and used only by qualified personnel. There are no warranties except as stated herein. There are no other warranties, expressed or implied, including but not limited to the implied warranties of merchantability and of fitness for a particular purpose. GEOKON is not responsible for any damages or losses caused to other equipment, whether direct, indirect, incidental, special or consequential which the purchaser may experience as a result of the installation or use of the product. The buyer's sole remedy for any breach of this agreement by GEOKON or any breach of any warranty by GEOKON shall not exceed the purchase price paid by the purchaser to GEOKON for the unit or units, or equipment directly affected by such breach. Under no circumstances will GEOKON reimburse the claimant for loss incurred in removing and/or reinstalling equipment.

Every precaution for accuracy has been taken in the preparation of manuals and/or software, however, GEOKON neither assumes responsibility for any omissions or errors that may appear nor assumes liability for any damages or losses that result from the use of the products in accordance with the information contained in the manual or software.

No part of this instruction manual may be reproduced, by any means, without the written consent of GEOKON. The information contained herein is believed to be accurate and reliable. However, GEOKON assumes no responsibility for errors, omissions or misinterpretation. The information herein is subject to change without notification.

The GEOKON® wordmark and logo are registered trademarks with the United States Patent and Trademark Office.

TABLE OF CONTENTS

1. INTRODUCTION	1
2. INSTALLATION	2
2.1 PRELIMINARY TESTS	2
2.2 EXTENSOMETER INSTALLATION	2
2.3 CABLE INSTALLATION AND SPLICING	3
2.4 INITIAL READINGS	4
2.5 ELECTRICAL NOISE	4
2.6 LIGHTNING PROTECTION	4
3. TAKING READINGS	5
3.1 GK-404 VIBRATING WIRE READOUT	5
3.1.1 OPERATING THE GK-404	5
3.2 GK-405 VIBRATING WIRE READOUT	5
3.2.1 CONNECTING SENSORS WITH 10-PIN BULKHEAD CONNECTORS ATTACHED	6
3.2.2 CONNECTING SENSORS WITH BARE LEADS	6
3.2.3 OPERATING THE GK-405	6
3.3 MEASURING TEMPERATURES	6
4. DATA REDUCTION	7
4.1 DIGITS	7
4.2 TEMPERATURE CORRECTION	9
5. TROUBLESHOOTING	11
APPENDIX A. SPECIFICATIONS	13
A.1 SPECIFICATIONS	13
A.2 THERMISTOR	13
APPENDIX B. THERMISTOR TEMPERATURE DERIVATION	14
APPENDIX C. ANCHOR PULLOUT TEST RESULTS	15
APPENDIX D. SWAGELOK TUBE FITTING	16
D.1 INSTALLATION	16
D.2 REASSEMBLY INSTRUCTIONS	16

FIGURES

FIGURE 1: MODEL 1300 (A-9) RETRIEVABLE EXTENSOMETER ANCHOR	1
FIGURE 2: MODEL 1300 (A-9) INSTALLATION	2
FIGURE 3: GK-404 READOUT	5
FIGURE 4: LEMO CONNECTOR TO GK-404	5
FIGURE 5: GK-405 READOUT	6
FIGURE 6: TYPICAL CALIBRATION REPORT	8
FIGURE 7: ANCHOR PULLOUT TEST RESULTS	15
FIGURE 8: TUBE INSERTION	16
FIGURE 9: MAKE A MARK AT SIX O'CLOCK	16
FIGURE 10: TIGHTEN ONE AND ONE-QUARTER TURNS	16
FIGURE 11: MARKS FOR REASSEMBLY	17
FIGURE 12: FERRULES SEATED AGAINST FITTING BODY	17
FIGURE 13: TIGHTEN NUT SLIGHTLY	17

TABLES

TABLE 1: ENGINEERING UNITS CONVERSION MULTIPLIERS	7
TABLE 2: THERMAL COEFFICIENT CALCULATION CONSTANTS	9
TABLE 3: THERMAL COEFFICIENTS OF EXPANSION FOR ROD MATERIALS.....	10
TABLE 4: SPECIFICATIONS	13
TABLE 5: 3KΩ THERMISTOR RESISTANCE.....	14

EQUATIONS

EQUATION 1: DIGITS CALCULATION	7
EQUATION 2: DEFORMATION CALCULATION	7
EQUATION 3: THERMALLY CORRECTED DEFORMATION CALCULATION.....	9
EQUATION 4: THERMAL COEFFICIENT CALCULATION	9
EQUATION 5: DEFORMATION METER LENGTH CORRECTION.....	9
EQUATION 6: ROD LENGTH TEMPERATURE CORRECTION.....	9
EQUATION 7: 3KΩ THERMISTOR RESISTANCE.....	14

1. INTRODUCTION

THEORY OF OPERATION

The GEOKON Model 1300 (A-9) Retrievable Extensometer is designed primarily for short-term measurements of deformation in boreholes in concrete, rock, etc. The system is used in both pre-cast and cast-in-place concrete piles in plate load tests in rock and anywhere deformations need to be measured in boreholes, either drilled or cast in to the structure being analyzed.

The system consists of pneumatically actuated anchors with spring-loaded transducers that are connected to one another in series by a single connecting rod. When installed, the anchors are fixed in place and the transducers measure the deformation between the anchor positions. The connecting rods are held in tension to eliminate errors due to bowing and friction. Connecting rods of fiberglass, graphite epoxy, and stainless steel are available.

The standard system is designed to be used in a pipe crafted of either plastic or steel, with an I.D. of 46 to 53 mm (1.811 to 2.086").

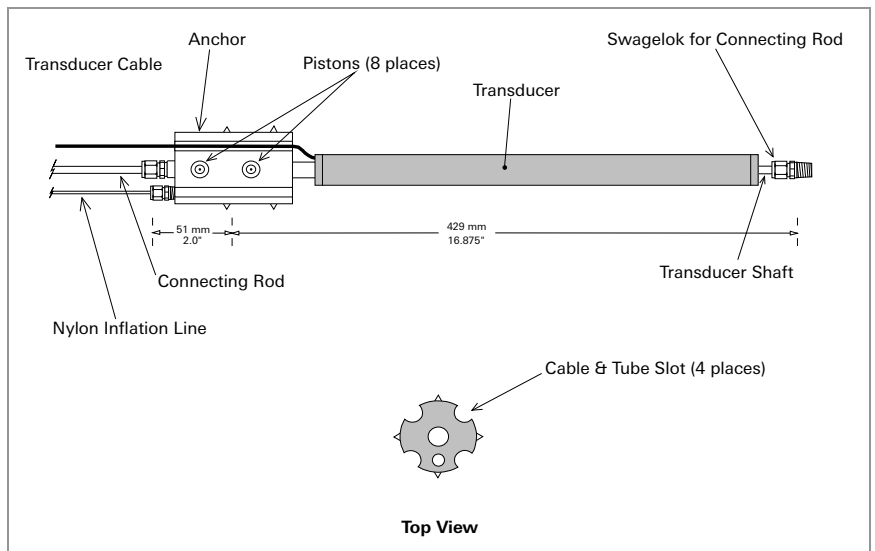

FIGURE 1: Model 1300 (A-9) Retrievable Extensometer Anchor

2. INSTALLATION

2.1 PRELIMINARY TESTS

Before assembly and installation of the extensometer, check the transducers for proper operation. See Section 3 for readout instructions. The GK-404 and GK-405 readouts the gauge will read between 2000 and 2500 in position **B**. The transducer may need to be slightly extended to get a reading. Pull on the Swagelok affixed to the transducer shaft to do this (see Figure 1).

Checks of electrical continuity can also be made using an ohmmeter. Resistance between the gauge leads should be approximately 180Ω , $\pm 10\Omega$. Remember to add the cable resistance, which is approximately 48.5Ω per km (14.7Ω per 1000') of 22 AWG stranded copper leads at 20 °C. Multiply this factor by two to account for both directions. Resistance between the green and white conductors will vary based on temperature; see Appendix B. Resistance between any conductor and the shield or the case of the sensor should exceed two megohms.

Checks on the actuation of the anchor pistons must be done with care. The anchor must first be positioned inside a piece of pipe or tubing with an inside diameter of approximately 50 mm (2"), before the pistons are actuated by pneumatic pressure. If the pneumatic pressure is applied to the pistons while the anchor is not inside a tube, the pistons will over-range and in the process the o-ring seals will be damaged, and the pistons will then be unable to hold pneumatic pressure without leaking.

Should any of these preliminary tests fail, see Section 5 for troubleshooting.

2.2 EXTENSOMETER INSTALLATION

An adequate area must be located for the assembly of the extensometer. Preferably it should be as long as the extensometer, clear of debris and obstructions. When assembling the extensometer in the field be especially careful to keep dirt out of the Swagelok fittings for the inflation lines.

1. Determine the anchor positions, i.e., the depth or position in the borehole for each anchor. Starting with the bottom (deepest) anchor, calculate the distance between it and the second anchor — *this is the increment over which the measurement will be made*.
2. The connecting rod must be cut to the proper length to make up this increment. For the standard 25 mm (1") transducer positioned at midrange, the length of the transducer assembly is 492 mm (19.375"). This length must be deducted from the increment length to make the correct rod length. For example, if the increment length is three meters, the rod length is 2.508 meters ($3.0 - 0.492 = 2.508$).
3. Calculate the rod lengths for all anchor positions and cut rods to length. Be careful when cutting the fiberglass rod that it does not splinter. Use a file to deburr the edges.
4. Connect the rod to the Swagelok fitting on the bottom anchor, pushing it in until it hits the shoulder. Tighten the Swagelok per instructions in Appendix D.
5. Connect the other end of the rod to the Swagelok fitting on the first transducer assembly. Repeat this for all the rods and sensors, leaving the instrument cables rolled up.
6. Attach an appropriate length of rod to the top anchor, this will allow for installation and removal of the system.

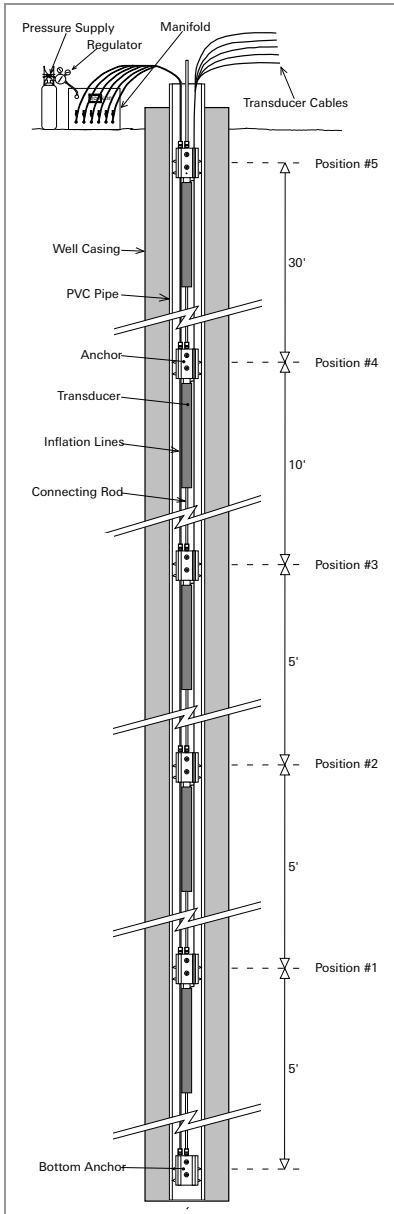

FIGURE 2: Model 1300 (A-9) Installation

7. Cut nylon inflation tubing for each anchor position. Allow enough tubing to connect to the pressure manifold.
8. Attach to the Swagelok fitting for the inflation line and tighten per the instructions in Appendix D.
9. Lay out all the transducer cables and inflation lines next to the anchors and attached rods.
10. Position the lines and cables in the slots of the anchors and tape on either side of the anchors, i.e., tape above the anchor around the connecting rod and below the anchor around the transducer body. Continue this procedure at each anchor position from the deepest up to the top. Be sure the inflation lines and transducer cables are clearly labeled. Allow enough slack, at least the range of the instrument (25 mm / 1") between anchor positions for the movement of the anchors.
11. The assembly is now ready for installation in the borehole. Lower the assembly into the borehole with the bottom anchor first. Bend the connecting rod through a large arc, as needed to lower the extensometer. Be careful not to permanently bend the rods.
12. Once the assembly is installed, attach the inflation lines to the pressure manifold. Attach the transducer cables to the terminal box or multiplexer.
13. Make sure all the valves of the pressure manifold are in the off position.
14. Attach the air supply to the pressure manifold. Carbon dioxide, compressed air, or nitrogen may be used for the pressure supply. The recommended pressure for setting the extensometer is 300 psi (20 bar). Appendix C illustrates the relationship between applied pressure and pullout of the anchor. The maximum recommended applied pressure is 750 psi (50 bar).
15. Turn on the air for the deepest position of the extensometer.
16. Attach the readout to the instrument cable from the first transducer position.
17. To set the transducer anchor pull on the extension rod coming out of the borehole until the desired reading is obtained and then turn on the valve for that position. To set the instrument at midrange the reading should be around 5000 digits. To measure mostly tensile strains the reading should be around 3000. To measure mostly compressive strains the reading should be around 7000. Repeat this procedure for each transducer position of the extensometer.

The installation is now complete.

2.3 CABLE INSTALLATION AND SPLICING

The cable should be routed to minimize the possibility of damage due to moving equipment, debris or other causes. The cable can be protected using flexible conduit, which can be supplied by GEOKON.

Terminal boxes with sealed cable entries are available from GEOKON for all types of applications. These allow many gauges to be terminated at one location with complete protection of the lead wires. The interior panel of the terminal box can have built-in jacks or a single connection with a rotary position selector switch. Contact GEOKON for specific application information.

Because the vibrating wire output signal is a frequency rather than a current or voltage, variations in cable resistance have little effect on gauge readings; therefore, splicing of cables has no ill effects, and in some cases may in fact be

beneficial. The cable used for making splices should be a high-quality twisted pair type, with 100% shielding and an integral shield drain wire. **When splicing, it is very important that the shield drain wires be spliced together.** Always maintain polarity by connecting color to color.

Splice kits recommended by GEOKON incorporate casts, which are placed around the splice and are then filled with epoxy to waterproof the connections. When properly made, this type of splice is equal or superior to the cable in strength and electrical properties. Contact GEOKON for splicing materials and additional cable splicing instructions.

Cables may be terminated by stripping and tinning the individual conductors and then connecting them to the patch cord of a readout box. Alternatively, a connector may be used which will plug directly into the readout box or to a receptacle on a special patch cord.

2.4 INITIAL READINGS

All readings are referred to the initial reading; it is very important that this initial reading be carefully taken. Conditions should be noted at the time of all readings, especially during curing, e.g., temperature, time after placement, local conditions, etc.

2.5 ELECTRICAL NOISE

Care should be exercised when installing instrument cables to keep them as far away as possible from sources of electrical interference such as power lines, generators, motors, transformers, arc welders, etc. **Cables should never be buried or run with AC power lines!** The instrument cables will pick up the 50 or 60 Hz (or other frequency) noise from the power cable and this will likely cause a problem obtaining a stable reading.

2.6 LIGHTNING PROTECTION

The Model 1300 (A-9) Retrievable Extensometer, unlike numerous other types of instrumentation available from GEOKON, does not have any integral lightning protection components, i.e., transzors or plasma surge arrestors. Usually this is not a problem however, if the instrument cable is exposed, it may be appropriate to install lightning protection components, as the transient could travel down the cable to the gauge and possibly destroy it.

NOTE:

- If the gauge is connected to a terminal box or multiplexer components such as plasma surge arrestors (spark gaps) may be installed in the terminal box/multiplexer to provide a measure of transient protection. Terminal boxes and multiplexers available from GEOKON provide locations for installation of these components.
- Lightning arrestor boards and enclosures are available from GEOKON that install near the instrument. The enclosure has a removable top, allowing access to the protection board. If the LAB-3 is damaged, the user may service the components or replace the board. A connection is made between this enclosure and earth ground to facilitate the passing of transients away from the gauge. Consult the factory for additional information on these or alternate lightning protection schemes.
- Plasma surge arrestors can be epoxy potted into the gauge cable close to the sensor. A ground strap would connect the surge arrestor to earth ground, either a grounding stake or other suitable earth ground.

3. TAKING READINGS



FIGURE 3: GK-404 Readout



FIGURE 4: Lemo Connector to GK-404

3.1 GK-404 VIBRATING WIRE READOUT

The Model GK-404 VV Readout is a portable, low-power, hand-held unit that is capable of running for more than 20 hours continuously on two AA batteries. It is designed for the readout of all GEOKON vibrating wire instruments, and is capable of displaying the reading in digits, frequency (Hz), period (μ s), or microstrain ($\mu\epsilon$). The GK-404 also displays the temperature of the transducer (embedded thermistor) with a resolution of 0.1 °C.

3.1.1 OPERATING THE GK-404

1. Attach the flying leads by aligning the red circle on the silver Lemo connector with the red line on the top of the GK-404 (see Figure 4). Insert the Lemo connector into the GK-404 until it locks into place.
2. Connect each of the clips on the leads to the matching colors of the sensor conductors, with blue representing the shield (bare).
3. To turn on the GK-404, press the **On/Off** button on the front panel of the unit. The initial startup screen will display.
4. After a delay, the GK-404 will start taking readings and display them based on the settings of the **Pos** and **Mode** buttons.

The unit display (from left to right) is as follows:

- The current position: set by the **Pos** button, displayed as A through F.
- The current reading: set by the **Mode** button, displayed as a numeric value followed by the unit of measure.
- Temperature reading of the attached instrument in degrees Celsius.

Use the **Pos** and **Mode** buttons to select the correct position and display units for the model of equipment purchased.

The GK-404 will continue to take measurements and display readings until the unit is turned off, either manually or by the Auto-Off timer (if enabled).

For more information, consult the GK-404 manual.

3.2 GK-405 VIBRATING WIRE READOUT

The GK-405 Readout is made up of two components:

- The Readout Unit, consisting of a Windows Mobile handheld PC running the GK-405 Vibrating Wire Readout application.
- The GK-405 Remote Module, which is housed in a weather-proof enclosure.

The remote module can be wire-connected to the sensor by means of:

- Flying leads with alligator clips if the sensor cable terminates in bare wires.
- A 10-pin connector.

The two units communicate wirelessly using Bluetooth[®], a reliable digital communications protocol. Using Bluetooth, the unit can operate from the cradle of the remote module, or, if more convenient, can be removed and operated up to 20 meters away from the remote module.

The GK-405 displays the thermistor temperature in degrees Celsius.



FIGURE 5: GK-405 Readout

For further details, consult the GK-405 Instruction Manual.

3.2.1 CONNECTING SENSORS WITH 10-PIN BULKHEAD CONNECTORS ATTACHED

Align the grooves on the sensor connector (male), with the appropriate connector on the readout (female connector, labeled sensor or load cell). Push the connector into place, and then twist the outer ring of the male connector until it locks into place.

3.2.2 CONNECTING SENSORS WITH BARE LEADS

Attach the flying leads to the bare leads of a GEOKON vibrating wire sensor by connecting each of the clips on the leads to the matching colors of the sensor conductors, with blue representing the shield (bare).

3.2.3 OPERATING THE GK-405

Press the power button on the Readout Unit. After start-up completes, a blue light will begin flashing, signifying that the two components are ready to connect wirelessly. Launch the GK-405 VWRA program by doing the following:

1. Tap Start on the hand-held PC's main window.
2. Select Programs.
3. Tap the GK-405 VWRA icon.

After a few seconds, the blue light should stop flashing and remain lit. The Live Readings window will display on the hand-held PC.

Set the Display mode to position **B**.

For more information, consult the GK-405 Instruction Manual.

3.3 MEASURING TEMPERATURES

All GEOKON vibrating wire instruments are equipped with a thermistor for reading temperature. The thermistor gives a varying resistance output as the temperature changes. The white and green leads of the instrument cable are normally connected to the internal thermistor.

The GK-404 and GK-405 readouts will read the thermistor and display the temperature in degrees Celsius.

TO READ TEMPERATURES USING AN OHMMETER:

1. Connect an ohmmeter to the green and white thermistor leads coming from the instrument. Since the resistance changes with temperature are large, the effect of cable resistance is usually insignificant. For long cables a correction can be applied equal to approximately 48.5Ω per km (14.7Ω per 1000') at 20 °C. Multiply these factors by two to account for both directions.
2. Look up the temperature for the measured resistance in Appendix B.

4. DATA REDUCTION

4.1 DIGITS

The basic units utilized by GEOKON for measurement and reduction of data from the vibrating wire deformation transducers used in the Model A-9 are "digits". The units displayed by the GK-404 and GK-405 in position "B" are digits. Calculation of digits is based on the following equation:

$$\text{digits} = \left(\frac{1}{\text{Period}} \right)^2 \times 10^{-3} \text{ or } \text{digits} = \frac{\text{Hz}^2}{1000}$$

EQUATION 1: Digits Calculation

To convert digits to deformation the following equation applies:

$$D = (R_1 - R_0) \times G \times F$$

EQUATION 2: Deformation Calculation

Where:

D is the calculated deformation.

R₁ is the current reading.

R₀ is the initial reading usually obtained at installation (see Section 2.4).

G is the calibration factor, usually in terms of millimeters or inches per digit taken from the calibration report, an example of which is shown in Figure 6.

F is an optional engineering units conversion factor, see the table below

To	From	Inches	Feet	Millimeters	Centimeters	Meters
Inches		1	12	0.03937	0.3937	39.37
Feet		0.0833	1	0.003281	0.03281	3.281
Millimeters		25.4	304.8	1	10	1000
Centimeters		2.54	30.48	0.10	1	100
Meters		0.0254	0.3048	0.001	0.01	1

TABLE 1: Engineering Units Conversion Multipliers

Example: The initial reading (R₀) with no load on the pile of a Model 1300 (A-9) transducer is 5102 digits. The reading with a 100-ton load on the pile, the current reading (R₁), is 4523. The calibration factor, G, is 0.0001755 inches/digit. The deformation change is:

$$D = (4523 - 5102) \times 0.0001755 = -0.1016 \text{ inches}$$

Note that decreasing readings (digits) indicate compression.

To calculate strain, divide the deformation by the distance between the anchors. For example, if the deformation change between two anchors spaced 12 feet apart was -0.1016 inches. The strain change for that segment of the pile, uncorrected for temperature, would be $-0.1016/144 \times 10^6 = -706 \mu\text{strain}$ (compression).



48 Spencer St. Lebanon, N.H. 03766 USA

Vibrating Wire Displacement Transducer Calibration Report

Range: 25 mm

Calibration Date: September 01, 2005

Serial Number: 05-8389

Temperature: 23.6 °C

Cal. Std. Control Numbers: 529, 406, 344, 057

Calibration Instruction: CI-4400 Rev: C

Technician: *Elice*

GK-401 Reading Position B

Actual Displacement (mm)	Gage Reading 1st Cycle	Gage Reading 2nd Cycle	Average Gage Reading	Calculated Displacement (Linear)	Error Linear (%FS)	Calculated Displacement (Polynomial)	Error Polynomial (%FS)
0.0	2230	2228	2229	-0.055	-0.22	-0.008	-0.03
5.0	3369	3368	3369	5.024	0.10	5.014	0.06
10.0	4494	4492	4493	10.04	0.14	9.999	0.00
15.0	5615	5613	5614	15.03	0.13	15.00	-0.02
20.0	6729	6729	6729	20.00	0.01	19.99	-0.03
25.0	7841	7841	7841	24.96	-0.17	25.01	0.02

(mm) Linear Gage Factor (G): 0.004457 (mm/ digit) Regression Zero: 2241

Polynomial Gage Factors: A: 1.11026E-08 B: 0.004345 C: -9.7486

(inches) Linear Gage Factor (G): 0.0001755 (inches/ digit)

Polynomial Gage Factors: A: 4.37111E-10 B: 0.0001711 C: -0.38380

Calculated Displacement:

Linear, $D = G(R_1 - R_0)$

Polynomial, $D = AR_1^2 + BR_1 + C$

Refer to manual for temperature correction information.

Function Test at Shipment:

GK-401 Pos. B: 4795

Temp(T_0): 23.7 °C

Date: September 19, 2005

The above instrument was found to be in tolerance in all operating ranges.
The above named instrument has been calibrated by comparison with standards traceable to the NIST, in compliance with ANSI Z540-1.
This report shall not be reproduced except in full without written permission of Geokon Inc.

FIGURE 6: Typical Calibration Report

4.2 TEMPERATURE CORRECTION

The Model 4430 Deformation Meter used in the Model 1300 (A-9) Extensometer has a vibrating wire transducer with a small coefficient of thermal expansion and the body of the transducer contracts and expands slightly with changes in temperature. The interconnecting rods also expand and contract; therefore, in most cases a correction is advisable. Note also that in situations where temperature changes are large (more than 10 degrees °C) it may be prudent to use carbon graphite rods that have very low coefficients of expansion. The following equation applies:

$$D_{corrected} = (R_1 - R_0) \times G + (T_1 - T_0) \times K + L_C + L_R$$

EQUATION 3: Thermally Corrected Deformation Calculation

Where:

R_1 is the Current Reading

R_0 is the Initial Reading

G is the Calibration Factor

T_1 is the Current Temperature

T_0 is the Initial Temperature

K is the calculated Thermal Coefficient

L_C is the correction for the change in gauge length

L_R is the correction for the change in rod length

Tests have determined that the Thermal Coefficient (K) of the transducer changes with the position of the transducer shaft. The first step in the temperature correction process is determination of the proper Thermal Coefficient based on the following equation:

$$\text{Thermal Coefficient} = ((\text{Reading in Digits} \times \text{Multiplier}) \text{ Constant}) \text{ Calibration Factor}$$

Or

$$K = ((R_1 \times M) + B) \times G$$

EQUATION 4: Thermal Coefficient Calculation

See the table below for the multiplier and constant values used in the previous equation. The Multiplier (M) and Constant (B) values vary for the stroke of the transducer used in the Deformation Meter.

Model:	4450-3 mm 4450-0.125"	4450-12 mm 4450-0.5"	4450-25 mm 4450-1"	4450-50 mm 4450-2"	4450-100 mm 4450-4"	4450-150 mm 4450-6"	4450-300 mm 4450-12"
Multiplier (M):	0.000520	0.000375	0.000369	0.000376	0.000398	0.000384	0.000424
Constant (B):	3.567	1.08	0.572	0.328	0.0864	-0.3482	-0.6778
Def Meter Length (L):	267 mm 10.5"	267 mm 10.5"	267 mm 10.5"	292 mm 11.5"	393 mm 15.49"	510.5 mm 20.1"	715.2 mm 28.2"

TABLE 2: Thermal Coefficient Calculation Constants

The Model 4430 deformation meter length temperature correction (L_C) is calculated using Equation 5.

$$L_C = 17.3 \times 10^{-6} \times L \times (T_1 - T_0)$$

EQUATION 5: Deformation Meter Length Correction

Where L is the length of deformation meter in millimeters or inches, (see Table 2).

The rod length correction (L_R) is calculated from the Equation 6:

$$L_R = K_R \times S \times (T_1 - T_0)$$

EQUATION 6: Rod Length Temperature Correction

Where:

S is the distance between anchor points minus the length of the transducer in mm or inches.

K_R is the coefficient of expansion of the rod material from the table below.

Rod Material	KR Thermal Coefficient Per °C
Stainless Steel	17.3×10^{-6}
Graphite	0.2×10^{-6}
Fiberglass	6.0×10^{-6}

TABLE 3: Thermal Coefficients of Expansion for Rod Materials

Example:

For the same 25 mm range transducer as before where the anchor spacing is 144 inches and the rods are fiberglass:

$$R_1 = 4523$$

$$T_o = 15 \text{ degrees } ^\circ\text{C}$$

$$T_1 = 30 \text{ degrees } ^\circ\text{C}$$

$$S = 144 - 10.5 = 133.5 \text{ inches}$$

$$\text{Then } K = [4523 \times 0.000369 + 0.572] \times 0.0001755 = 0.00039$$

The total temperature correction is:

$$(T_1 - T_o) [K + L_C + L_R] = (30 - 15) \times [0.00039 + 10.5 \times 17.3 \times 10^{-6} + 133.5 \times 6.0 \times 10^{-6}] \\ = +0.0206 \text{ inches}$$

The total deformation, temperature corrected, is $-0.1016 + 0.0206 = -0.081$ inches, and the measured strain is $-0.081/144 \times 10^6 = -562$ microstrain in compression.

5. TROUBLESHOOTING

Maintenance and troubleshooting is confined to periodic checks of cable connections and maintenance of terminals. Once installed, these instruments are usually inaccessible and remedial action is limited. Should difficulties arise, consult the following list of problems and possible solutions. Return any faulty gauges to the factory. **Instruments should not be opened in the field.** For additional troubleshooting and support, contact GEOKON.

SYMPTOM: THERMISTOR RESISTANCE IS TOO HIGH

- Check for an open circuit. Check all connections, terminals, and plugs. If a cut is located in the cable, splice according to instructions in .

SYMPTOM: THERMISTOR RESISTANCE IS TOO LOW

- Check for a short circuit. Check all connections, terminals, and plugs. If a short is located in the cable, splice according to instructions in .
- Water may have penetrated the interior of the instrument. There is no remedial action.

SYMPTOM: INSTRUMENT READINGS ARE UNSTABLE

- Is the readout box position set correctly? If using a datalogger to record readings automatically, are the swept frequency excitation settings correct?
- Is there a source of electrical noise nearby? Likely candidates are generators, motors, arc welding equipment, high voltage lines, etc. If possible, move the instrument cable away from power lines and electrical equipment or install electronic filtering.
- Make sure the shield drain wire is connected to ground. Connect the shield drain wire to the readout using the blue clip.
- Does the readout or datalogger work with another instrument? If not, it may have a low battery or possibly be malfunctioning.

SYMPTOM: TRANSDUCER WILL NOT HOLD PRESSURE

- Check all the fittings on the pneumatic lines using a soap solution and observe for bubbles. If no leaks are found then the o-ring on the anchor piston may be cut or nicked. Replace the o-ring using one of the spares from the accessories supplied with the equipment. The piston is held inside the anchor by a small "ding" made by a prick punch. This has to be filed off with a round file so that the piston can be pushed out. Replace the o-ring and push the piston back into place. Once again, "ding" the end of the hole with a hammer and screwdriver so that the piston is once again held in place.

SYMPTOM: INSTRUMENT FAILS TO READ

- Does the readout or datalogger work with another instrument? If not, it may have a low battery or possibly be malfunctioning.
- Is the cable cut or crushed? Check the resistance of the cable by connecting an ohmmeter to the sensor leads; resistance is approximately 48.5 Ω per km (14.7 Ω per 1000') of 22 AWG wire.
- If the resistance is very high or infinite, the cable is probably broken. If the resistance is very low, the conductors may be shorted. If a break or a short is present, splice according to the instructions in Section 2.3.

Refer to the expected resistance for the various wire combinations below.

Vibrating Wire Sensor Lead Resistance Levels

Red/Black $\cong 180\Omega$

Green/White 3000 at 25 °C

Any other wire combination will result in a measurement of infinite resistance.

APPENDIX A. SPECIFICATIONS

A.1 SPECIFICATIONS

Ranges Available: ¹	12.5, 25, 50, 100, 150, 200 mm (0.5, 1, 2, 4, 6, 8")
Accuracy:	±0.1%
Resolution:	0.025% F.S.
Linearity:	< 0.5% F.S.
Thermal Zero Shift:	< 0.05% F.S./°C
Stability:	< 0.2%/yr (under static conditions)
Temperature Range:	-40 to +60 °C Note: Model 1300-3 (A-9) manifold is not rated for use below +10 °C ¹
Frequency Range:	1400 - 3500 Hz
Coil Resistance:	180Ω, 10Ω
Cable Type: ²	Two twisted pair (four conductor) 22 AWG, Foil shield, PVC jacket, nominal OD = 4.8 mm (0.1875")
Rod Types:	Stainless steel, fiberglass, graphite
Required Pipe I.D.:	46 to 53 mm (1.811 to 2.086")

TABLE 4: Specifications

Notes:

¹ Consult the factory for other ranges available.

² Consult the factory for alternate cable types.

A.2 THERMISTOR

Range: -80 to +150 °C

Accuracy: ±0.5 °C

APPENDIX B. THERMISTOR TEMPERATURE DERIVATION

3KΩ THERMISTOR RESISTANCE

Thermistor Types:

- YSI 44005, Dale #1C3001-B3, Alpha #13A3001-B3
- Honeywell 192-302LET-A01

Resistance to Temperature Equation:

$$T = \frac{1}{A+B(\ln R)+C(\ln R)^3} - 273.15$$

EQUATION 7: 3kΩ Thermistor Resistance

Where:

T = Temperature in °C

LnR = Natural Log of Thermistor Resistance

A = 1.4051 x 10⁻³

B = 2.369 x 10⁻⁴

C = 1.019 x 10⁻⁷

Note: Coefficients calculated over the -50 to +150 °C span.

Ohms	Temp	Ohms	Temp	Ohms	Temp	Ohms	Temp	Ohms	Temp
201.1K	-50	15.72K	-9	2221	32	474.7	73	137.2	114
187.3K	-49	14.90K	-8	2130	33	459.0	74	133.6	115
174.5K	-48	14.12K	-7	2042	34	444.0	75	130.0	116
162.7K	-47	13.39K	-6	1959	35	429.5	76	126.5	117
151.7K	-46	12.70K	-5	1880	36	415.6	77	123.2	118
141.6K	-45	12.05K	-4	1805	37	402.2	78	119.9	119
132.2K	-44	11.44K	-3	1733	38	389.3	79	116.8	120
123.5K	-43	10.86K	-2	1664	39	376.9	80	113.8	121
115.4K	-42	10.31K	-1	1598	40	364.9	81	110.8	122
107.9K	-41	9796	0	1535	41	353.4	82	107.9	123
101.0K	-40	9310	1	1475	42	342.2	83	105.2	124
94.48K	-39	8851	2	1418	43	331.5	84	102.5	125
88.46K	-38	8417	3	1363	44	321.2	85	99.9	126
82.87K	-37	8006	4	1310	45	311.3	86	97.3	127
77.66K	-36	7618	5	1260	46	301.7	87	94.9	128
72.81K	-35	7252	6	1212	47	292.4	88	92.5	129
68.30K	-34	6905	7	1167	48	283.5	89	90.2	130
64.09K	-33	6576	8	1123	49	274.9	90	87.9	131
60.17K	-32	6265	9	1081	50	266.6	91	85.7	132
56.51K	-31	5971	10	1040	51	258.6	92	83.6	133
53.10K	-30	5692	11	1002	52	250.9	93	81.6	134
49.91K	-29	5427	12	965.0	53	243.4	94	79.6	135
46.94K	-28	5177	13	929.6	54	236.2	95	77.6	136
44.16K	-27	4939	14	895.8	55	229.3	96	75.8	137
41.56K	-26	4714	15	863.3	56	222.6	97	73.9	138
39.13K	-25	4500	16	832.2	57	216.1	98	72.2	139
36.86K	-24	4297	17	802.3	58	209.8	99	70.4	140
34.73K	-23	4105	18	773.7	59	203.8	100	68.8	141
32.74K	-22	3922	19	746.3	60	197.9	101	67.1	142
30.87K	-21	3748	20	719.9	61	192.2	102	65.5	143
29.13K	-20	3583	21	694.7	62	186.8	103	64.0	144
27.49K	-19	3426	22	670.4	63	181.5	104	62.5	145
25.95K	-18	3277	23	647.1	64	176.4	105	61.1	146
24.51K	-17	3135	24	624.7	65	171.4	106	59.6	147
23.16K	-16	3000	25	603.3	66	166.7	107	58.3	148
21.89K	-15	2872	26	582.6	67	162.0	108	56.8	149
20.70K	-14	2750	27	562.8	68	157.6	109	55.6	150
19.58K	-13	2633	28	543.7	69	153.2	110		
18.52K	-12	2523	29	525.4	70	149.0	111		
17.53K	-11	2417	30	507.8	71	145.0	112		
16.60K	-10	2317	31	490.9	72	141.1	113		

TABLE 5: 3KΩ Thermistor Resistance

APPENDIX C. ANCHOR PULLOUT TEST RESULTS

Pullout tests were conducted with the Model 1300 (A-9) anchors installed in stainless steel and PVC pipes to determine the force necessary to fail the anchors.

The results are presented in the following chart.

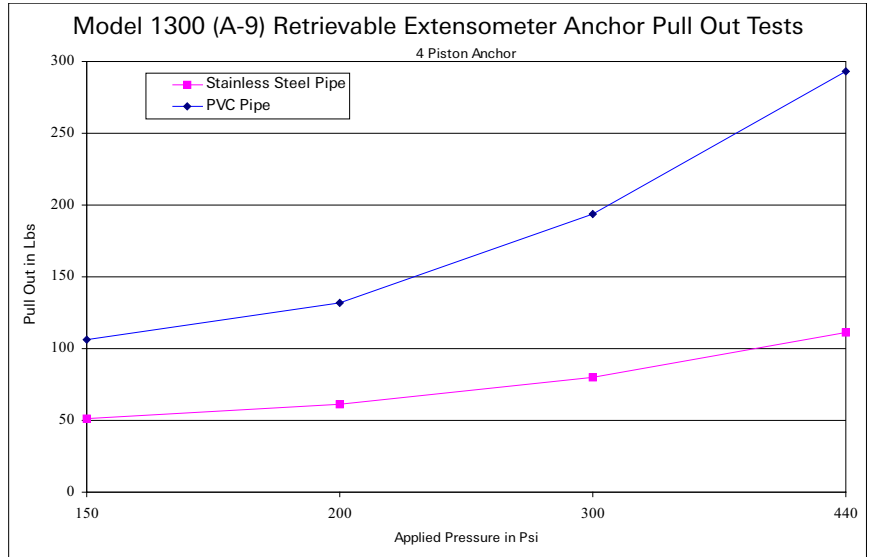

FIGURE 7: Anchor Pullout Test Results

APPENDIX D. SWAGELOK TUBE FITTING

These instructions apply to 25 mm (1") and smaller fittings.

D.1 INSTALLATION

1. Fully insert the tube into the fitting until it bumps against the shoulder.

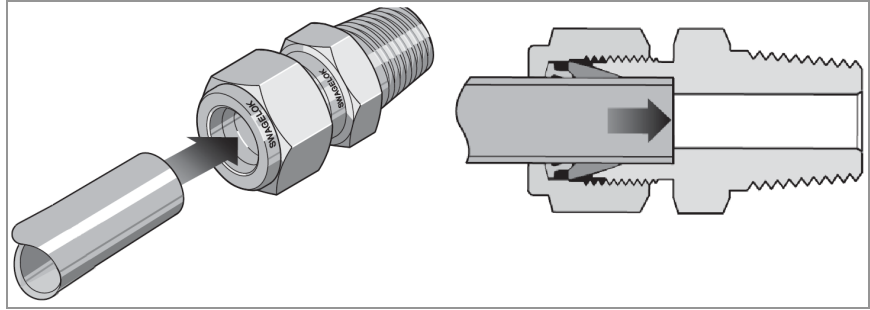

FIGURE 8: Tube Insertion

2. Rotate the nut until it is finger-tight. For high-pressure applications as well as high-safety-factor systems, further tighten the nut until the tube will not turn by hand or move axially in the fitting.
3. Mark the nut at the six o'clock position.

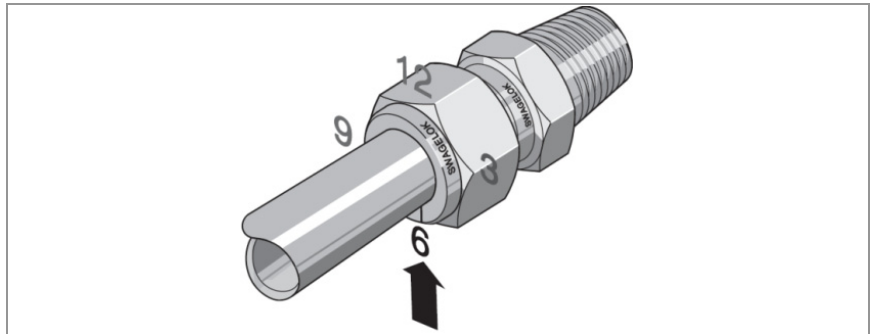

FIGURE 9: Make a Mark at Six O'Clock

4. While holding the fitting body steady, tighten the nut one and one-quarter turns until the mark is at the nine o'clock position.

Note: For $\frac{1}{16}$ ", $\frac{1}{8}$ ", $\frac{3}{16}$ ", and 2, 3, and 4 mm fittings, tighten the nut three-quarters of a turn until the mark is at the three o'clock position.

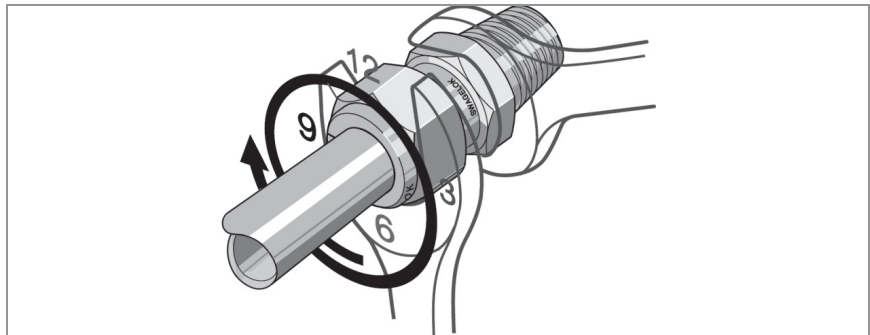

FIGURE 10: Tighten One and One-Quarter Turns

D.2 REASSEMBLY INSTRUCTIONS

Swagelok tube fittings can be disassembled and reassembled many times.

Warning! Always depressurize the system before disassembling a Swagelok tube fitting.

1. Prior to disassembly, mark the tube at the back of the nut, then make a line along the nut and fitting body flats. **These marks will be used during reassembly to ensure the nut is returned to its current position.**

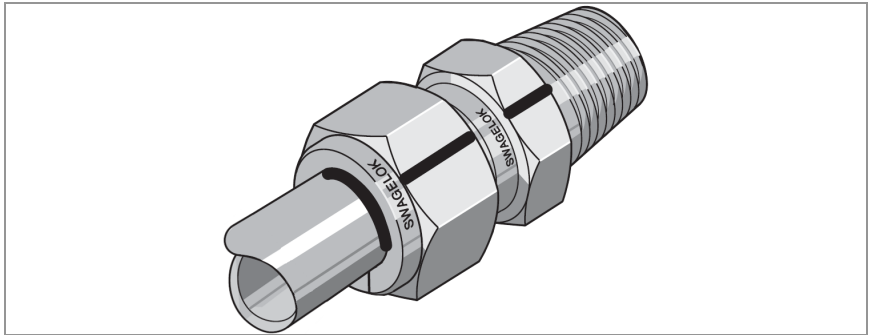

FIGURE 11: Marks for Reassembly

2. Disassemble the fitting.
3. Inspect the ferrules for damage and replace if necessary. **If the ferrules are replaced the connector should be treated as a new assembly. Refer to the section above for installation instructions.**
4. Reassemble the fitting by inserting the tube with preswaged ferrules into the fitting until the front ferrule seats against the fitting body.

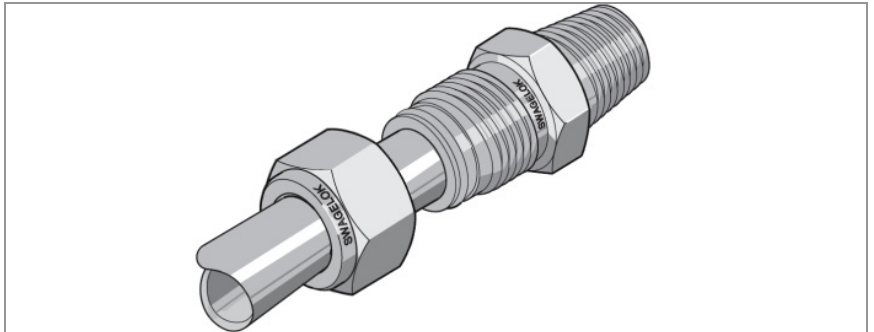

FIGURE 12: Ferrules Seated Against Fitting Body

5. While holding the fitting body steady, rotate the nut with a wrench to the previous position as indicated by the marks on the tube and the connector. At this point, there will be a significant increase in resistance.
6. Tighten the nut slightly.

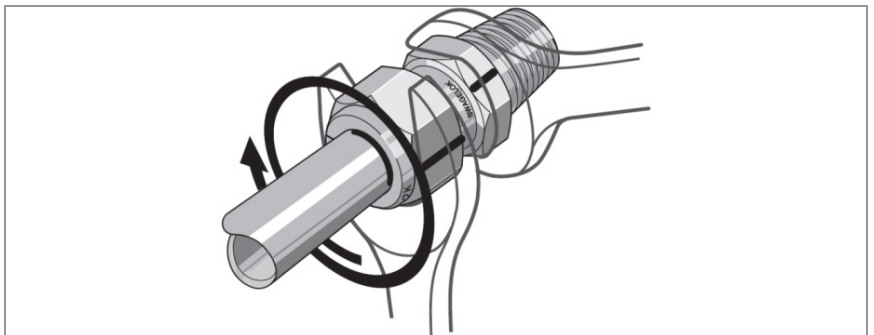

FIGURE 13: Tighten Nut Slightly

GEOKON®

GEOKON
48 Spencer Street
Lebanon, New Hampshire
03766, USA

Phone: +1 (603) 448-1562
Email: info@geokon.com
Website: www.geokon.com

GEOKON
is an **ISO 9001:2015**
registered company