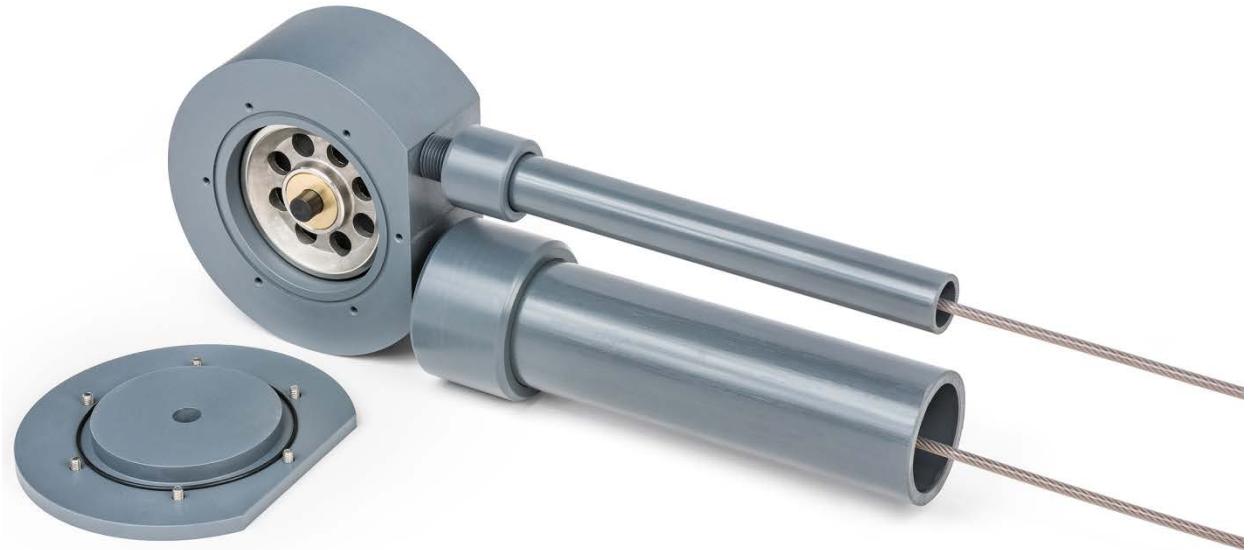




*The World Leader in Vibrating Wire Technology*

48 Spencer Street  
Lebanon, NH 03766, USA  
Tel: 603•448•1562  
Fax: 603•448•3216  
E-mail: [geokon@geokon.com](mailto:geokon@geokon.com)  
<http://www.geokon.com>

*Instruction Manual*  
**Dead End Pulley**  
**Models 4651-3 and 6015-4**



No part of this instruction manual may be reproduced, by any means, without the written consent of Geokon, Inc.

The information contained herein is believed to be accurate and reliable. However, Geokon, Inc. assumes no responsibility for errors, omissions or misinterpretation. The information herein is subject to change without notification.

Copyright, 2017 by Geokon, Inc.  
(INITIAL 12/18 /17)



## *Warranty Statement*

Geokon, Inc. warrants its products to be free of defects in materials and workmanship, under normal use and service for a period of 13 months from date of purchase. If the unit should malfunction, it must be returned to the factory for evaluation, freight prepaid. Upon examination by Geokon, if the unit is found to be defective, it will be repaired or replaced at no charge. However, the WARRANTY is VOID if the unit shows evidence of having been tampered with or shows evidence of being damaged as a result of excessive corrosion or current, heat, moisture or vibration, improper specification, misapplication, misuse or other operating conditions outside of Geokon's control. Components which wear or which are damaged by misuse are not warranted. This includes fuses and batteries.

Geokon manufactures scientific instruments whose misuse is potentially dangerous. The instruments are intended to be installed and used only by qualified personnel. There are no warranties except as stated herein. There are no other warranties, expressed or implied, including but not limited to the implied warranties of merchantability and of fitness for a particular purpose. Geokon, Inc. is not responsible for any damages or losses caused to other equipment, whether direct, indirect, incidental, special or consequential which the purchaser may experience as a result of the installation or use of the product. The buyer's sole remedy for any breach of this agreement by Geokon, Inc. or any breach of any warranty by Geokon, Inc. shall not exceed the purchase price paid by the purchaser to Geokon, Inc. for the unit or units, or equipment directly affected by such breach. Under no circumstances will Geokon reimburse the claimant for loss incurred in removing and/or reinstalling equipment.

Every precaution for accuracy has been taken in the preparation of manuals and/or software, however, Geokon, Inc. neither assumes responsibility for any omissions or errors that may appear nor assumes liability for any damages or losses that result from the use of the products in accordance with the information contained in the manual or software.

## TABLE of CONTENTS

<b>1. INTRODUCTION .....</b>	<b>1</b>
<b>2. INSTALLATION.....</b>	<b>2</b>

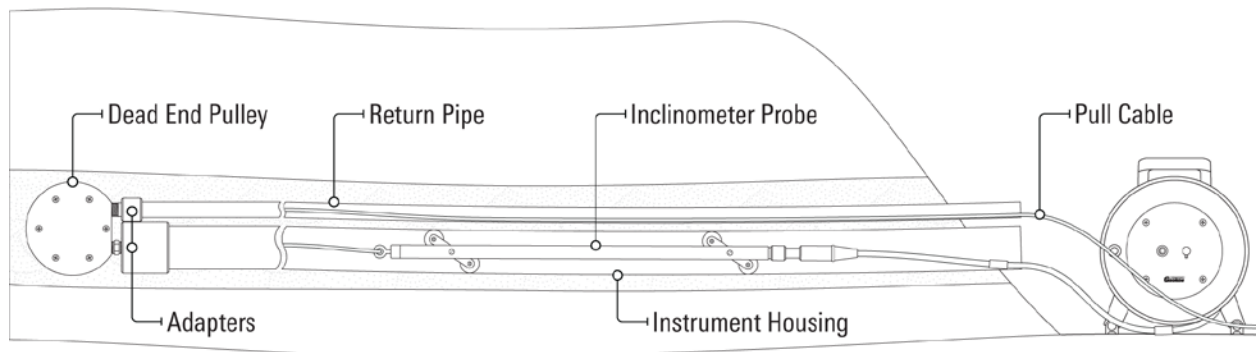
## FIGURES

Figure 1 - Horizontal Probe using Dead End Pulley System .....	1
Figure 2 - Settlement Profiler using Dead End Pulley System .....	1
Figure 3 - Dead End Pulley Diagram.....	2
Figure 4 - Dead End Pulley Using Fiberglass Casing.....	3

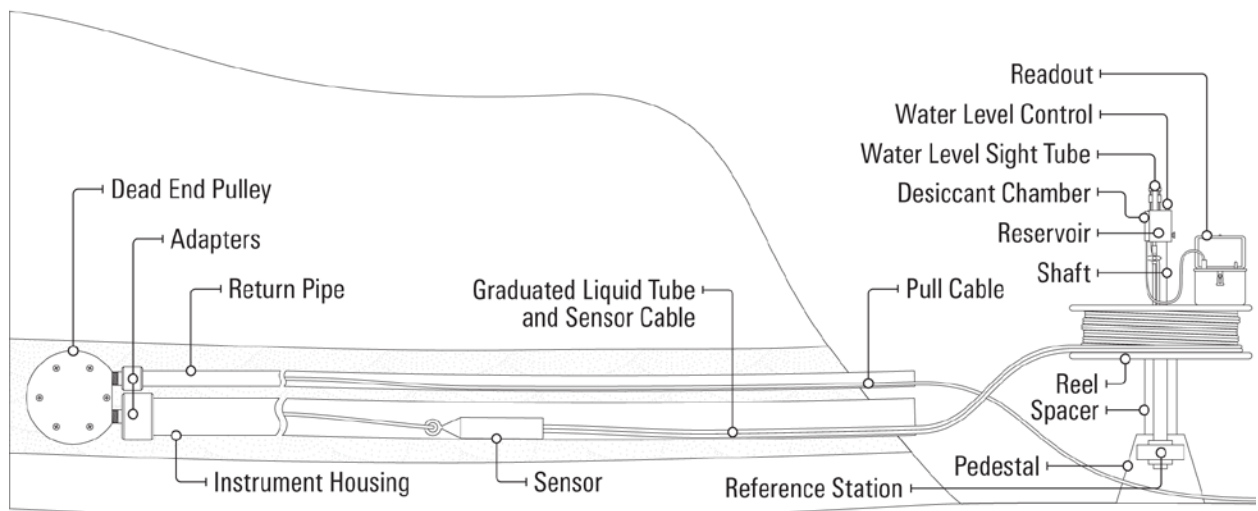
## **1. INTRODUCTION**

When an inclinometer probe or settlement profiler is installed in a horizontal borehole, the casing of PVC that houses the instrument can be open at both ends, or closed at the far end. When the instrument housing is closed at the far end, a dead end pulley and cable return pipe are required. Geokon's dead end pulley allows the operation of the pull cable from a single end of the housing, as shown in Figure 1 and Figure 2.

The pulley assembly may be positioned horizontally or vertically in the fill. It comes with two 1/2-14 NPT threads for mounting of adapters, which must be specified by the customer to ensure proper mating to the customer's instrument housing.

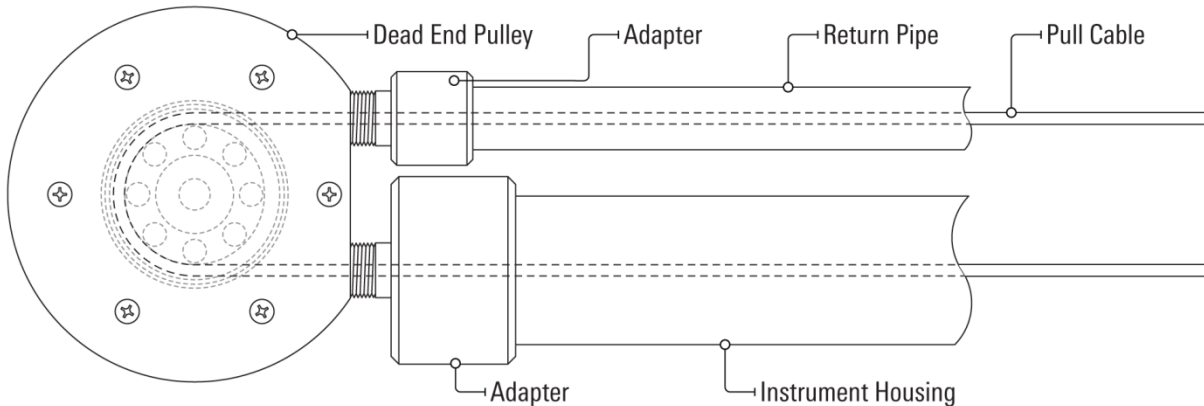


**Figure 1 - Horizontal Probe using Dead End Pulley System**



**Figure 2 - Settlement Profiler using Dead End Pulley System**

## **2. INSTALLATION**



**Figure 3 - Dead End Pulley Diagram**

Referring to Figure 3, install the dead end pulley as follows:

- 1) For most orders, the pull cable will be installed onto the pulley at the factory. If the pull cable is already installed, skip to step three, if not, continue to step two.
- 2) Push the pull cable into the pulley housing until it emerges on the opposite side.  
If the cable will not push through the assembly, it may be necessary to take the cap off by loosening the six 10-32 flat head screws. Once the cap has been removed, align the cable on the pulley. Next, reassemble the cap, making sure that the O-ring in the cap seals correctly.
- 3) Thread the pull cable through the return pipe.
- 4) Attach the return pipe to the adapter on the dead end pulley using PVC primer and cement.
- 5) Thread the pull cable through the instrument housing.
- 6) Attach the instrument housing to the adapter on the dead end pulley as follows:

**For PVC tubing and smooth walled casing:** Use PVC primer and cement.

**For grooved fiberglass casing:** Use rivets or self-tapping screws. Place Butyl Tape (Geokon part number ADH-129) around the edge of the casing and over the installed rivets/screws. See Figure 4 below.



**Figure 4 - Dead End Pulley Using Fiberglass Casing**

- 7) Continue assembling the return pipe and instrument housing, working away from the dead end pulley.

Installation complete.