

**GEOKON**®

48 Spencer Street  
Lebanon, NH 03766, USA  
Tel: 603-448-1562  
Fax: 603-448-3216  
Email: [geokon@geokon.com](mailto:geokon@geokon.com)  
<http://www.geokon.com>

*Instruction Manual*  
**Model 6155**  
**MEMS Horizontal In-Place Incliner**



No part of this instruction manual may be reproduced, by any means, without the written consent of Geokon®.

The information contained herein is believed to be accurate and reliable. However, Geokon® assumes no responsibility for errors, omissions or misinterpretation. The information herein is subject to change without notification.

Copyright © 2005-2022 by Geokon®  
(Doc REV, L 09/14/22)



## ***Warranty Statement***

Geokon warrants its products to be free of defects in materials and workmanship, under normal use and service for a period of 13 months from date of purchase. If the unit should malfunction, it must be returned to the factory for evaluation, freight prepaid. Upon examination by Geokon, if the unit is found to be defective, it will be repaired or replaced at no charge. However, the WARRANTY is VOID if the unit shows evidence of having been tampered with or shows evidence of being damaged as a result of excessive corrosion or current, heat, moisture or vibration, improper specification, misapplication, misuse or other operating conditions outside of Geokon's control. Components which wear or which are damaged by misuse are not warranted. This includes fuses and batteries.

Geokon manufactures scientific instruments whose misuse is potentially dangerous. The instruments are intended to be installed and used only by qualified personnel. There are no warranties except as stated herein. There are no other warranties, expressed or implied, including but not limited to the implied warranties of merchantability and of fitness for a particular purpose. Geokon is not responsible for any damages or losses caused to other equipment, whether direct, indirect, incidental, special or consequential which the purchaser may experience as a result of the installation or use of the product. The buyer's sole remedy for any breach of this agreement by Geokon or any breach of any warranty by Geokon shall not exceed the purchase price paid by the purchaser to Geokon for the unit or units, or equipment directly affected by such breach. Under no circumstances will Geokon reimburse the claimant for loss incurred in removing and/or reinstalling equipment.

Every precaution for accuracy has been taken in the preparation of manuals and/or software, however, Geokon neither assumes responsibility for any omissions or errors that may appear nor assumes liability for any damages or losses that result from the use of the products in accordance with the information contained in the manual or software.



# TABLE of CONTENTS

<b>1. INTRODUCTION .....</b>	<b>1</b>
1.1 TILT SENSOR CONSTRUCTION.....	1
<b>2. INSTALLATION .....</b>	<b>2</b>
2.1 PRELIMINARY TESTS.....	2
2.2 MODEL 6155 MEMS ASSEMBLY AND INSTALLATION .....	2
2.3 CONNECTION TO SWITCH – BOXES OR DATALOGGER –STANDARD SYSTEM.....	3
<b>3. TAKING READINGS.....</b>	<b>4</b>
3.1 DATALOGGERS .....	4
3.2 RB-500 READOUT BOX .....	4
3.3 MEASURING TEMPERATURE .....	4
<b>4. DATA REDUCTION .....</b>	<b>5</b>
4.1 SETTLEMENT CALCULATION .....	5
4.2 TEMPERATURE CORRECTION .....	5
4.3 SETTLEMENT CALCULATION .....	5
4.4 ENVIRONMENTAL FACTORS.....	6
<b>5. TROUBLESHOOTING.....</b>	<b>8</b>
<b>APPENDIX A. SPECIFICATIONS.....</b>	<b>9</b>
A.1 MEMS TILT SENSOR .....	9
A.2 THERMISTOR (SEE APPENDIX B ALSO).....	9
<b>APPENDIX B. THERMISTOR TEMPERATURE DERIVATION.....</b>	<b>ERROR! BOOKMARK NOT DEFINED.</b>
<b>APPENDIX C. WIRING CODE .....</b>	<b>11</b>
<b>APPENDIX D. 6155 STANDARD ADDRESSABLE SYSTEMS.....</b>	<b>12</b>
<b>APPENDIX E. PROGRAMMING THE MEMS INCLINOMETER WITH CRBASIC.....</b>	<b>14</b>
<b>APPENDIX F. PROGRAMMING THE ADDRESSABLE MEMS INCLINOMETER WITH CRBASIC.....</b>	<b>15</b>

## FIGURES

FIGURE 1 - MODEL 6155 MEMS TILT SENSOR ASSEMBLY .....	1
FIGURE 2 - MODEL 6155 MEMS INSTALLATION .....	1
FIGURE 3 - SETTLEMENT INTERVALS .....	5
FIGURE 4 - SAMPLE MODEL 6155 MEMS CALIBRATION SHEET .....	7
FIGURE 5 - THERMISTOR BRIDGE CIRCUIT.....	13

## TABLES

TABLE 1 - MODEL 6155 MEMS TILT SENSOR SPECIFICATIONS .....	9
TABLE 2 - THERMISTOR RESISTANCE VERSUS TEMPERATURE .....	<b>ERROR! BOOKMARK NOT DEFINED.</b>
TABLE 3 - CABLE 03-250V0 WIRING.....	11
TABLE 4 - CABLE 06-312V0 WIRING.....	11
TABLE 5 - ADDRESSABLE MEMS (LOGIC LEVEL STYLE) WIRING .....	12

## EQUATIONS

EQUATION 1 - INCLINATION VERSUS VOLTS.....	5
EQUATION 2 - INCLINATION VERSUS VOLTS CORRECTED FOR TEMPERATURE.....	5
EQUATION 3 - VERTICAL OFFSET CALCULATION.....	6
EQUATION 4 - SETTLEMENT CALCULATION .....	6
EQUATION 5 - CONVERT THERMISTOR RESISTANCE TO TEMPERATURE .....	<b>ERROR! BOOKMARK NOT DEFINED.</b>

## 1. INTRODUCTION

The Geokon Model 6155 MEMS Horizontal In-Place Inclinator system is designed for long term monitoring of differential settlements beneath structures such as dams, landfills, embankments, storage tanks and the like. The basic principle is the utilization of tilt sensors to make accurate measurement of inclination, over segments, in boreholes drilled into the structure being studied. The continuous nature of the instrument allows for very precise measurement of changes in the borehole profile to be measured. The instrument is installed in standard grooved inclinometer casing.

See Figure 1.

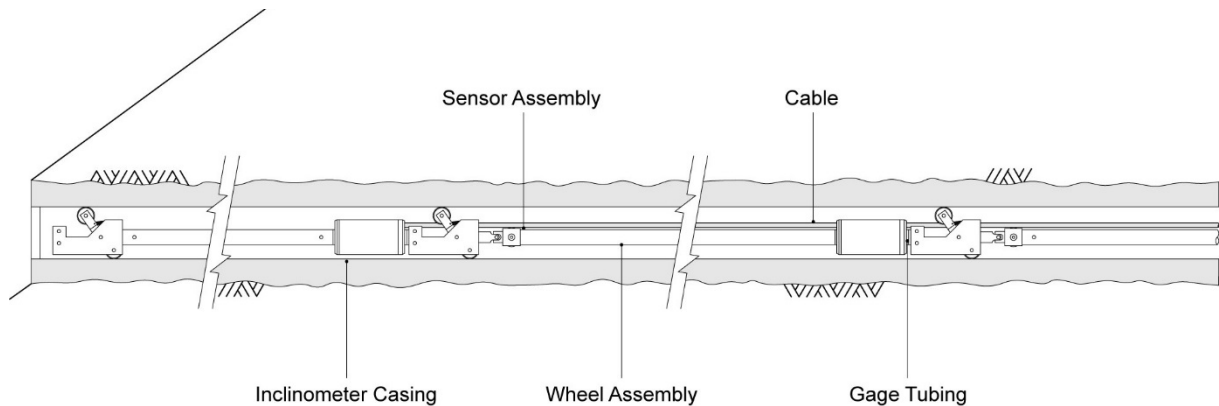

Figure 1 - Model 6155 MEMS Tilt Sensor Assembly

### 1.1 Tilt Sensor Construction

The sensor comprises a Micro-Electro-Mechanical Systems, (MEMS), mounted inside a sealed housing. The Housing has a mounting bracket on its nearest end for connecting the sensor to a wheel assembly, which guides the sensors along the vertical pair of grooves in standard inclinometer casing. A lug on the nearest end of the wheel assembly connects to a universal coupling, (which allows unimpeded relative movement between the spacing rods), and a swivel joint, (which accommodates any spiraling of the casing, and prevents the wheel assemblies from running out of the casing grooves). Stainless steel tubing is used to connect and space apart the sensors and wheel assemblies, and the whole string is installed from one end of the casing. Each housing contains a thermistor for reading temperatures.

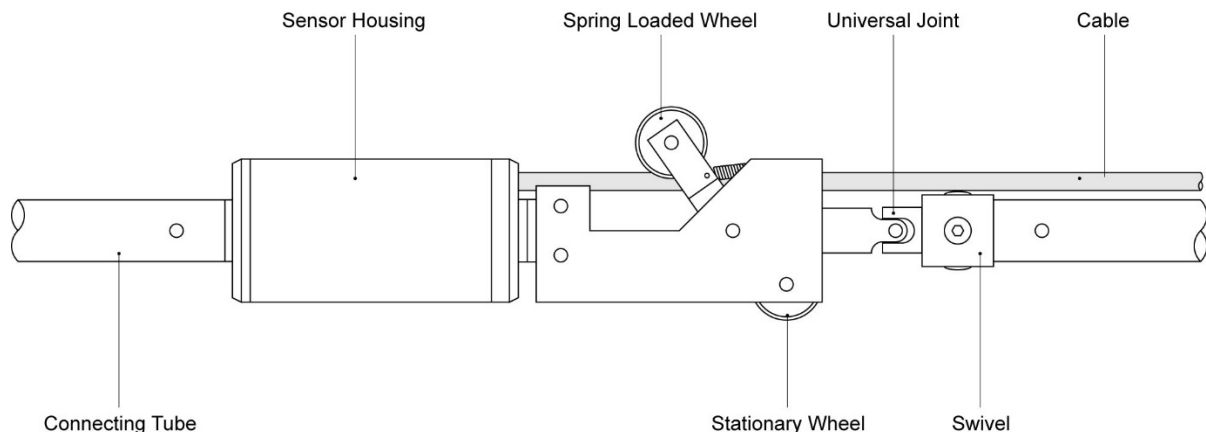

Figure 2 - Model 6155 MEMS Installation

## **2. INSTALLATION**

### **2.1 Preliminary Tests**

Prior to installation, the sensors need to be checked for proper operation. Each tilt sensor is supplied with a calibration sheet, which shows the relationship between output voltage and inclination. The tilt sensor electrical leads are connected to a Datalogger or RB-500 readout box (see Section 3) and the current reading compared to the calibration readings. Carefully hold the sensor in an approximately horizontal position and observe the reading. The sensor must be held in a steady position. The readings should be close to the factory vertical reading. The temperature indicated by the thermistor should be close to ambient.

Checks of electrical continuity can also be made using an ohmmeter. Resistance between any conductor and the shield or the case should exceed two megohms.

### **2.2 Model 6155 MEMS Assembly and Installation**

The 6155 MEMS Assembly is intended for use in inclinometer casing that has been installed so that one pair of grooves is vertical.

1. The first sensor assembly is made up as follows:  
Take the end wheel assembly – the one that has no universal joint – and connect it to the first rod – one that has the correct length – using a 10-32 cap screw and nut. Use thread-locking compound on the threads. Note: Tubing joints are purposely made to close tolerances. If the screws will not pass through the joint, it must be reamed with the drill provided (.193").  
Now select a tilt sensor and bolt it to the other end of the rod using a 10-32 cap screw and nut, (use thread-locking compound on the threads), so that when the fixed wheel is on the bottom the plus sign on the tilt sensor is on the top.  
Now attach the sensor to the next wheel assembly, (complete with universal coupling and swivel joint), using two 10-32 screws and nuts, and a thread locking cement to make this joint.
2. Connect the safety cable, if used, to the end wheel assembly and push the first sensors assembly into the casing while keeping the safety cable and sensor cable from becoming entangled. Make sure that the fixed wheel of the wheel assembly is in the bottom groove of the casing.
3. The second sensor assembly is made up as follows:  
Select the next rod and connect it to the next sensor using a 10-32 cap screw and nut. Use thread-locking compound on the threads. Connect the sensor to the next wheel assembly, (complete with universal coupling and swivel joint), using two 10-32 screws and nuts, and a thread locking cement to make this joint.  
Now connect the rod of the second wheel assembly to the swivel joint of the first sensor assembly and push the second sensor assembly into the borehole making sure once again that the plus sign on the sensor is uppermost and the fixed wheel of the wheel assembly is in the bottom casing groove.
4. Proceed as above with the remaining sensors making sure to correctly identify the positions of the various sensors and to keep the various cables from becoming entangled. The cables from the lower sensors should be taped or tie-wrapped to the assembly at intervals to prevent interference as the system is built up and lowered down the borehole.



5. After the sensor string is pushed into position and the final wheel assembly has been installed inside the mouth of the casing, it can be locked in place using wooden wedges. The safety cable can be tied off around the end of the casing and the signal cables can be run to the readout location and terminated at a switch box or otherwise fixed. Readings can be taken immediately after installation, but it is recommended that the system be allowed to stabilize for a few hours before recording zero conditions.

### **2.3 Connection to Switch – Boxes or Datalogger –Standard System**

For manual readout using an RB-500 readout box, cables from the individual sensors are connected to a switchbox using the wiring code shown in Appendix C. If a datalogger is used the cables are connected directly to the Multiplexer using the same wiring code.

## **3. TAKING READINGS**

### **3.1 Dataloggers**

In most cases the 6155 MEMS In-Place Inclinometer will be monitored continuously and automatically using a Datalogger. Connections to the Geokon Model 8021 Micro-1000 Datalogger, which uses a Campbell Scientific CR1000 MCU, are shown in Appendix C.

### **3.2 RB-500 Readout Box**

The RB-500 readout box is designed to take readings for manually transcribing into a field book; it has no storage capabilities. This method is useful for reading systems that do not require continuous monitoring. The RB-500 readout box is also useful during initial installations and for setting up Datalogger systems.

**Note that the RB-500 Readout Box uses a 2:1 voltage divider to halve the full-scale output of the MEMS sensor, which is  $\pm 4$  volts. This is done so that the  $\pm 2$ -volt DVM in the RB-500 readout box can display the full output range of the MEMS sensor.**

### **3.3 Measuring Temperature**

Although the temperature dependence of the MEMS tilt meter is practically zero, and does not require compensation, it sometimes happens that temperature effects can cause real changes of tilt; therefore, each MEMS tilt sensor is equipped with a thermistor for reading temperature. This enables temperature-induced changes in tilt to be distinguished from tilts due to other sources. The thermistor gives a varying resistance output as the temperature changes. Check the instrument wiring codes for the thermistor connections.

1. The RB-500 cannot read temperatures; a separate digital ohmmeter is required. Connect an ohmmeter to the two thermistor leads coming from the tilt sensor. (Since the resistance changes with temperature are so large, the effect of cable resistance is usually insignificant.)

## **4. DATA REDUCTION**

### **4.1 Settlement Calculation**

The output of the MEMS Sensor is proportional to the sine of the angle of inclination from the horizontal. For the  $\pm 15$ -degree sensor the FS output is approximately  $\pm 4$  volts.

The relationship between the readings, **R**, in volts displayed on channels A and B on the RB-500 readout box, and the angle of inclination,  $\theta$ , is given by the equation:

$$\theta = \text{Sin}^{-1}(\text{RG}) \quad \text{or} \quad \text{Sin}\theta = \text{RG}$$

**Equation 1 - Inclination versus volts.**

Where **R** is the current reading in volts and **G** is the Gauge Factor shown on the calibration sheet. Note that the small zero reading at zero inclination can be ignored since it is only the change of inclination that is of interest. If the orientation of the sensors has been performed as described, with the plus sign on the sensor uppermost, then positive outputs will correspond to a settlement of the furthest end of the rod segment relative to the near end.

### **4.2 Temperature Correction**

The Model 6155 MEMS Tiltmeter has zero temperature sensitivity. The tilt corrected for temperature is, as before:

$$\text{Sin}\theta_{\text{temp corrected}} = \text{RG degrees}$$

**Equation 2 - Inclination versus volts corrected for Temperature.**

Temperature corrections are not required. An important point to note is that sudden changes in temperature will cause both the structure and the Tiltmeter to undergo transitory physical changes, which will show up in the readings. The gauge temperature should always be recorded, and efforts should be made to obtain readings when the instrument and structure are at thermal equilibrium. The best time for this tends to be in the late evening or early morning hours.

### **4.3 Settlement Calculation**

The vertical offset, **D**, of the far end of any segment relative to the near end of the segment is equal to  $L\text{sin}\theta$ , where **L** is the length of the segment, between wheel bearings, and  $\theta$  is the inclination of the segment to the horizontal. The vertical profile of the casing is constructed by using the cumulative sum of these vertical offsets starting with the nearest segment, **L<sub>1</sub>**. For instance, referring to Figure 3.



**Figure 3 - Settlement Intervals**

The total vertical offset of the far end of the casing relative to the near end of the casing is

$$D_5 = L_1 \sin \theta_1 + L_2 \sin \theta_2 + L_3 \sin \theta_3 + L_4 \sin \theta_4 + L_5 \sin \theta_5$$

**Equation 3 - Vertical Offset Calculation**

Therefore, ignoring temperature corrections,

$$D_5 = G_1 L_1 R_1 + G_2 L_2 R_2 + G_3 L_3 R_3 + G_4 L_4 R_4 + G_5 L_5 R_5$$

And the settlement,  $\Delta D$ , i.e. the change in vertical offset is

$$\Delta D_n = \sum_1^n G_n L_n \Delta R_n$$

**Equation 4 - Settlement Calculation**

Where  $\Delta R_1 = (R_1 - R_0)$  i.e. the present reading on Sensor 1 minus the initial reading on Sensor 1; and  $\Delta R_2 = (R_2 - R_0)$  i.e. the present reading on Sensor 2 minus the initial reading on Sensor 2; and similarly, for all the other Sensors.

#### **4.4 Environmental Factors**

Since the purpose of the 6155 MEMS installation is to monitor site conditions, factors that may affect these conditions should be observed and recorded. Seemingly minor effects may have a real influence on the behavior of the structure being monitored and may give an early indication of potential problems. Some of these factors include, but are not limited to: blasting, rainfall, tidal or reservoir levels, excavation and fill levels and sequences, traffic, temperature and barometric changes, changes in personnel, nearby construction activities, seasonal changes, etc.

<b>GEOKON</b>		48 Spencer St. Lebanon, N.H. 03766 USA				
<b>MEMS Tilt Sensor Calibration</b>						
Model Number: <u>MEMS Tilt Sensor</u>			Calibration Date: <u>March 12, 2015</u>			
Serial Number: <u>Sensor A 1500141</u>			Calibration Instruction: <u>CI-Tiltmeter MEMS</u>			
Temperature: <u>22.5 °C</u>			Technician:			
Inclination (degrees)	Inclination (sinθ)	* Reading 1st Cycle (Volts)	* Reading 2nd Cycle (Volts)	* Average Reading (Volts)	Error in Calculated θ (%FS)	
15.00	0.2588	4.051	4.051	4.0507	-0.15	0.01
14.00	0.2419	3.781	3.781	3.7808	-0.09	-0.01
12.00	0.2079	3.241	3.241	3.2410	0.02	-0.01
10.00	0.1736	2.696	2.696	2.6963	0.08	-0.02
8.00	0.1392	2.148	2.149	2.1485	0.10	-0.03
6.00	0.1045	1.599	1.600	1.5995	0.11	-0.02
4.00	0.0698	1.047	1.047	1.0472	0.07	-0.03
2.00	0.0349	0.494	0.494	0.4939	0.02	-0.03
0.00	0.0000	-0.058	-0.058	-0.0577	0.00	0.00
-2.00	-0.0349	-0.612	-0.612	-0.6120	-0.06	-0.01
-4.00	-0.0698	-1.165	-1.165	-1.1646	-0.10	0.00
-6.00	-0.1045	-1.716	-1.716	-1.7160	-0.12	0.01
-8.00	-0.1392	-2.266	-2.266	-2.2661	-0.13	0.00
-10.00	-0.1736	-2.813	-2.813	-2.8132	-0.10	0.00
-12.00	-0.2079	-3.358	-3.357	-3.3575	-0.04	-0.01
-14.00	-0.2419	-3.899	-3.899	-3.8987	0.06	-0.02
-15.00	-0.2588	-4.167	-4.167	-4.1672	0.14	-0.03
<b>6150, 6155 and 6170 In-Place Inclinometer Gage Factor (D): <u>0.0630</u> (sinθ/ Volt)</b>						
<b>Deflection = DL(R<sub>1</sub>-R<sub>0</sub>) mm (inches)</b>						
<b>6160 and 6165 Tiltmeter Gage Factor (G): <u>3.640</u> (degrees/ Volt) over + / - 15° range</b>						
<b>Calculated Tilt = G(R<sub>1</sub> - R<sub>0</sub>) degrees</b>						
<b>Temperature Correction Factor -0.0003 (T<sub>1</sub>-T<sub>0</sub>) Volts / °C</b>						
Wiring Code: See manual for further information						
The above instrument was found to be in tolerance in all operating ranges. The above named instrument has been calibrated by comparison with standards traceable to the NIST, in compliance with ANSI Z540-1. This report shall not be reproduced except in full without written permission of Geokon Inc.						

Figure 4 - Sample Model 6155 MEMS Calibration Sheet

## **5. TROUBLESHOOTING**

Maintenance and troubleshooting of the vibrating wire tilt sensors used in the Model 6155 MEMS Horizontal Inclinometer are confined to periodic checks of cable connections. The sensors are sealed and there are no user serviceable parts.

Consult the following list of problems and possible solutions should difficulties arise. Consult the factory for additional troubleshooting help.

### ***Symptom: Tilt Sensor Readings are Unstable:***

- ✓ Is there a source of electrical noise nearby? Most probable sources of electrical noise are motors, generators and antennas. Make sure the shield drain wire is connected to ground whether using a portable readout or datalogger.
- ✓ Does the readout work with another tilt sensor? If not, the readout may have a low battery or be malfunctioning.

### ***Symptom: Tilt Sensor Fails to Read:***

- ✓ Is the cable cut or crushed? This can be checked with an ohmmeter. The nominal resistance of the thermistor is 3000 ohms at 25 degrees C. If the approximate temperature is known, the resistance of the thermistor leads can be estimated and used as a cable check. Remember to add cable resistance when checking (22 AWG stranded copper leads are approximately  $14.7\Omega/1000'$  or  $48.5\Omega/\text{km}$ , multiply by two for both directions). If the resistance reads infinite, or very high (megohms), a cut wire must be suspected. If the resistance reads very low ( $<20\Omega$ ) a short in the cable is likely.
- ✓ Does the readout or datalogger work with another tilt sensor? If not, the readout or datalogger may be malfunctioning.

### ***Symptom: Thermistor resistance is too high:***

- ✓ Is there an open circuit? Check all connections, terminals and plugs.

### ***Symptom: Thermistor resistance is too low:***

- ✓ Is there a short? Check all connections, terminals and plugs.
- ]✓ Water may have penetrated the interior of the tilt sensor. There is no remedial action.

## **APPENDIX A. SPECIFICATIONS**

### **A.1 MEMS Tilt Sensor**

<b>Model:</b>	<b>6155</b>
<b>Range</b>	$\pm 15^\circ$
<b>Resolution:<sup>1</sup></b>	$\pm 4$ arc seconds, ( $\pm 0.02$ mm/m)
<b>Accuracy<sup>2</sup></b>	$\pm 10$ arc seconds, ( $\pm 0.05$ mm/m)
<b>Linearity:<sup>3</sup></b>	$\pm 0.07\%$ FS
<b>Cross axis sensitivity</b>	4%
<b>Sensor Output</b>	$\pm 4$ Volts (nominal) @ $\pm 15$ degrees
<b>Thermal Zero Shift:</b>	0.0003 volt/ $^\circ$ C rise
<b>Operating Temperature</b>	-20 to $+80^\circ$ C -4 to $176^\circ$ F
<b>Power Requirements:</b>	6155-1 (Uniaxial): +12V (nom) @ 30mA (9V min. / 15Vmax.) 6155-2 (Biaxial): +12V (nom) @ 45mA (9V min. / 15Vmax.)
<b>Sensor Output:</b>	$\pm 4$ Volts @ FS
<b>Frequency Response:</b>	-3db @ 8-28 Hz
<b>Shock Resistance</b>	20,000g
<b>Thermistor Resistance:</b>	3000 $\Omega$ at $25^\circ$ C
<b>Sensor Housing Dia.:</b>	32 mm, (1.250").
<b>Length and Diameter:</b>	219 mm x 32 mm (6155A-1/2), 362 mm x 32 mm (others).
<b>Weight:</b>	0.4 kg. (0.9 lbs.).
<b>Materials:</b>	304 Stainless Steel
<b>Electrical Cable:</b>	Three twisted pair (six conductor) 24 AWG Foil shield, Polyurethane jacket, nominal OD = 6.3 mm Or Six twisted pair (12 conductor) 24 AWG Foil shield, Polyurethane jacket, nominal OD = 7.9 mm

**Table 1 - Model 6155 MEMS Tilt Sensor Specifications**

Notes:

<sup>1</sup> For best results requires a 4 ½ digit digital voltmeter.

Averaging will yield resolution on the order of two arc seconds

<sup>2</sup> Based upon the use of a second order polynomial

<sup>3</sup> The output of the MEMS sensor is proportional to the sine of the angle of tilt

### **A.2 Thermistor (see Appendix Error! Reference source not found. also)**

Range: -80 to  $+150^\circ$  C

Accuracy:  $\pm 0.5^\circ$  C

## APPENDIX B. THERMISTOR TEMPERATURE DERIVATION

Thermistor Type: YSI 44005, Dale #1C3001-B3, Alpha #13A3001-B3  
 Resistance to Temperature Equation:

$$T = \frac{1}{A+B(\ln R)+C(\ln R)^3} - 273.15 \text{ } ^\circ\text{C}$$

**Equation 5 - Resistance to Temperature**

Where;

T = Temperature in °C.

LnR = Natural Log of Thermistor Resistance.

A = 1.4051 × 10<sup>-3</sup>

B = 2.369 × 10<sup>-4</sup>

C = 1.019 × 10<sup>-7</sup>

Note: Coefficients calculated over the -50 to +150° C. span.

Ohms	Temp	Ohms	Temp	Ohms	Temp	Ohms	Temp	Ohms	Temp
201.1K	-50	16.60K	-10	2417	+30	525.4	+70	153.2	+110
187.3K	-49	15.72K	-9	2317	31	507.8	71	149.0	111
174.5K	-48	14.90K	-8	2221	32	490.9	72	145.0	112
162.7K	-47	14.12K	-7	2130	33	474.7	73	141.1	113
151.7K	-46	13.39K	-6	2042	34	459.0	74	137.2	114
141.6K	-45	12.70K	-5	1959	35	444.0	75	133.6	115
132.2K	-44	12.05K	-4	1880	36	429.5	76	130.0	116
123.5K	-43	11.44K	-3	1805	37	415.6	77	126.5	117
115.4K	-42	10.86K	-2	1733	38	402.2	78	123.2	118
107.9K	-41	10.31K	-1	1664	39	389.3	79	119.9	119
101.0K	-40	9796	0	1598	40	376.9	80	116.8	120
94.48K	-39	9310	+1	1535	41	364.9	81	113.8	121
88.46K	-38	8851	2	1475	42	353.4	82	110.8	122
82.87K	-37	8417	3	1418	43	342.2	83	107.9	123
77.66K	-36	8006	4	1363	44	331.5	84	105.2	124
72.81K	-35	7618	5	1310	45	321.2	85	102.5	125
68.30K	-34	7252	6	1260	46	311.3	86	99.9	126
64.09K	-33	6905	7	1212	47	301.7	87	97.3	127
60.17K	-32	6576	8	1167	48	292.4	88	94.9	128
56.51K	-31	6265	9	1123	49	283.5	89	92.5	129
53.10K	-30	5971	10	1081	50	274.9	90	90.2	130
49.91K	-29	5692	11	1040	51	266.6	91	87.9	131
46.94K	-28	5427	12	1002	52	258.6	92	85.7	132
44.16K	-27	5177	13	965.0	53	250.9	93	83.6	133
41.56K	-26	4939	14	929.6	54	243.4	94	81.6	134
39.13K	-25	4714	15	895.8	55	236.2	95	79.6	135
36.86K	-24	4500	16	863.3	56	229.3	96	77.6	136
34.73K	-23	4297	17	832.2	57	222.6	97	75.8	137
32.74K	-22	4105	18	802.3	58	216.1	98	73.9	138
30.87K	-21	3922	19	773.7	59	209.8	99	72.2	139
29.13K	-20	3748	20	746.3	60	203.8	100	70.4	140
27.49K	-19	3583	21	719.9	61	197.9	101	68.8	141
25.95K	-18	3426	22	694.7	62	192.2	102	67.1	142
24.51K	-17	3277	23	670.4	63	186.8	103	65.5	143
23.16K	-16	3135	24	647.1	64	181.5	104	64.0	144
21.89K	-15	<b>3000</b>	<b>25</b>	624.7	65	176.4	105	62.5	145
20.70K	-14	2872	26	603.3	66	171.4	106	61.1	146
19.58K	-13	2750	27	582.6	67	166.7	107	59.6	147
18.52K	-12	2633	28	562.8	68	162.0	108	58.3	148
17.53K	-11	2523	29	543.7	69	157.6	109	56.8	149
								55.6	150

**Table 2 - Thermistor Resistance Versus Temperature**



## **APPENDIX C. WIRING CODE**

03-250V0 cable	Connector Pin Designation	Uniaxial MEMS <b>with</b> Thermistor	Connector Pin Designation	Biaxial MEMS <b>without</b> Thermistor
Red	A	12VDC	A	12VDC
Red's Black	B	Ground	B	Ground
White	C	A Out Diff +	C	A Out Diff +
White's Black	D	A Out Diff -	D	A Out Diff -
Bare	E	Shield	E	Shield
Green	J	Thermistor	F	B Out Diff +
Green's Black	K	Thermistor	G	B Out Diff -

**Table 3 - Cable 03-250V0 Wiring**

06-312V0 Cable	Connector Pin Designation	Biaxial MEMS <b>with</b> Thermistor
Red	A	12VDC
Red's Black	B	Ground
White	C	A Out Diff +
White's Black	D	A Out Diff -
Bare	E	Shield
Green	F	B Out Diff +
Green's Black	G	B Out Diff -
Blue	J	Thermistor
Blue's Black	K	Thermistor

**Table 4 - Cable 06-312V0 Wiring**

## **APPENDIX D. 6155 STANDARD ADDRESSABLE SYSTEMS**

### **Description:**

The standard 6155 addressable system incorporates a Distributed Multiplexer Circuit Board that allows multiple MEMS type Inclinometers, uniaxial or biaxial, to be connected as “drops” off of a single bus.

The Inclinometer “string” is addressed via ENABLE and CLOCK signals in the same manner as the Geokon Model 8032-16 Channel Multiplexer.

The addressable Inclinometer string is “enabled” by raising the appropriate Datalogger Control Port to 5V. After the string has been enabled, a delay of 125 mS is required before executing the 1<sup>st</sup> of the two clock pulses required to activate the 1<sup>st</sup> channel. Once the channel is selected, a delay of 100 mS is required for the sensor to warm up. The sensor’s A-axis is read 100 times and then the average of these readings is stored. The sensors B-axis is then read. Finally, the sensor’s thermistor is read through a bridge completion circuit and the temperature is calculated using a polynomial formula. Examples of CRBASIC programming can be found in Appendix E and Appendix F.

### **Wiring:**

06-312V0 Cable Color	Connector Pin Designation	Addressable MEMS System (Logic Level Style)
Yellow	A	A-axis Output Differential +
Yellow’s Black	B	A-axis Output Differential -
Brown	C	B-axis Output Differential +
Brown’s Black	D	B-axis Output Differential -
Red	E	12VDC
Red’s Black	F	Ground
White	G	Reset
White’s Black	H	Ground
Green	J	Clock
Green’s Black	K	Ground
Blue	L	Thermistor*
Blue’s Black	M	Thermistor*
Bare	P	Shield

**Table 5 - Addressable MEMS (Logic Level Style) Wiring**

\* 1K and 5K precision resistors are used to complete the thermistor bridge circuit:

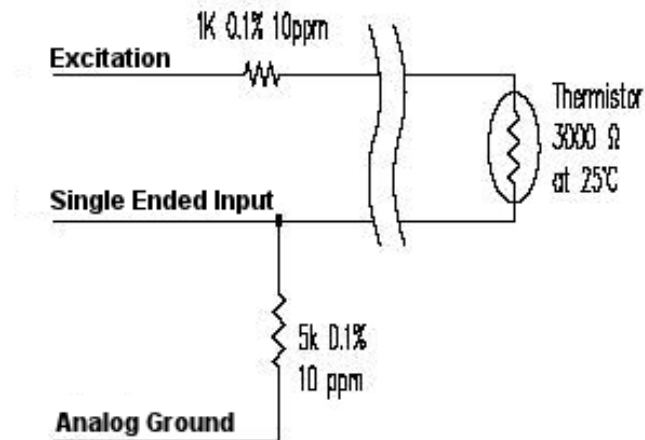

Figure 5 - Thermistor Bridge Circuit

**Specifications for Addressable System (Logic Level Style) Circuit Board:**

Board Dimensions:	4.5"(L) x 1.155"(W) x 0.4"(H)
Power Requirements:	+12V ( $\pm 3V$ ) 110mA (max) when active 700uA (max) standby
Operating Temperature:	-20 to +70° C
Contact Resistance:	100 m $\Omega$ (typ)
Contact Breakdown Voltage:	1500 Vrms
Relay open/close time:	4mS (max)

## **APPENDIX E. PROGRAMMING THE MEMS INCLINOMETER WITH CRBASIC**

### **Description:**

CRBASIC is the programming Language used with Campbell Scientific CRBASIC Dataloggers. Campbell's LoggerNet Software is typically used when programming in CRBASIC. The MEMS sensor should be read with the VoltDiff instruction and the output averaged 100x. No Thermistor in this example.

### **Sample Program:**

#### ***'Declare Public Variables for Reading MEMS Sensor***

```
Public MEMS_1
Public MEMS_2
Public MEMS_3
Public MEMS_Output 'Output of the MEMS Sensor
```

#### ***'Store MEMS Output every 2 minutes***

```
DataTable (MEMS_EXAMPLE,1,-1)
    Sample (1,MEMS_Output,IEEE4)
EndTable
```

```
BeginProg
```

#### ***'2 min scan interval***

```
Scan (2,min,0,0)
```

#### ***'Read MEMS Sensor on Differential Channel 1 and average 100x Readings***

```
Delay(0,100,mSec)
MEMS_3 = 0
For MEMS_1 = 1 To 100
    VoltDiff (MEMS_2,1,mV5000,1,False,0,250,0.001,0)
    MEMS_3 = MEMS_3 + MEMS_2
Next
```

```
MEMS_Output = MEMS_3 / 100
```

```
CallTable MEMS_EXAMPLE
```

```
NextScan
```

```
EndProg
```

## **APPENDIX F. PROGRAMMING THE ADDRESSABLE MEMS INCLINOMETER WITH CRBASIC**

### **Description:**

CRBASIC is the programming Language used with Campbell Scientific CRBASIC Dataloggers. Campbell's LoggerNet Software is typically used when programming in CRBASIC. The MEMS sensor should be read with the VoltDiff instruction and the output averaged 100x.

### **Sample Program:**

**'The following sample program reads 20 addressable Bi-Axial MEMS Gauges and Thermistors. The A-Axis is read on Differential Channel 1, the B-Axis is read on Differential Channel 2 and the Thermistors are read with Single Ended Channel 5 and the bridge excited with EX1. The string is enabled with Control Port 1 and clocked with control port 8.**

### ***'Declare Public Variables for Reading MEMS Sensor and Thermistor***

```
Public MEMS_1
Public MEMS_2
Public MEMS_3
Public THERM_1
Public THERM_2
Public THERM_3
Public Channel 'Counter
Public Reading_A 'Output of the A Axis
Public Reading_B 'Output of the B Axis
Public Reading_THERM 'Output of Thermistor
```

### **'Store MEMS Output every 5 minutes**

```
DataTable (MEMS_EXAMPLE,1,-1)
    Sample (1,Reading_A,IEEE4)
    Sample (1,Reading_B,IEEE4)
    Sample (1,Reading_THERM,IEEE4)
EndTable
```

```
BeginProg
```

### **'5 min scan interval**

```
Scan (5,min,0,0)
```

### **'enable String using C1**

```
PortSet(1,1)
```

### **'Delay**

```
Delay(0,125,MSEC)
```

**'counter for number of sensors**

For Channel = 1 To 20

**'1st clock using C8**

PortSet(8,1)

Delay(0,10,MSEC)

PortSet(8,0)

Delay(0,10,MSEC)

**'Delay**

Delay(0,100,mSec)

**'Read the A-axis****'Reset the temporary storage location**

MEMS\_3 = 0

**'counter**

For MEMS\_1 = 1 To 100

**'differential voltage measurement on DIFF1**

VoltDiff (MEMS\_2,1,mV5000,1,False,0,1000,0.001,0)

**'Sum the readings**

MEMS\_3 = MEMS\_3 + MEMS\_2

**'Increment To 100**

Next

**'Calculate the Average reading value**

Reading\_A = MEMS\_3 / 100

**'Read the B-axis****'Reset the temporary storage location**

MEMS\_3 = 0

**'counter**

For MEMS\_1 = 1 To 100

**'differential voltage measurement on DIFF2**

VoltDiff (MEMS\_2,1,mV5000,2,False,0,1000,0.001,0)

**'Sum the readings**

MEMS\_3 = MEMS\_3 + MEMS\_2

**'Increment To 100**

Next

**'Calculate the Average reading value**

Reading\_B = MEMS\_3 / 100

**'Delay**

Delay(0,100,msec)

**'Read the thermistor**

**'half bridge measurement - SE5 AND EX1**

BrHalf(THERM\_1,1,mV2500,5,VX1,1,2500,0,1000,250,2.5,0.0)

**'Calculate the temperature**

THERM\_2 = THERM\_1 / 5000

THERM\_3 = (2.5 - (THERM\_2\*1000) - THERM\_1)/THERM\_2

Reading\_THERM = 1/(.0014051 + (.0002369\*LOG(THERM\_3)) +  
(.0000001019\*(LOG(THERM\_3)^3))) - 273.2

**'2nd clock using C8**

PortSet(8,1)

Delay(0,10,MSEC)

PortSet(8,0)

Delay(0,10,MSEC)

**'Next sensor**

Next

**'Disable String**

PortSet(1,0)

CallTable MEMS\_EXAMPLE

NextScan

EndProg