



48 Spencer Street  
Lebanon, NH 03766, USA  
Tel: 603-448-1562  
Fax: 603-448-3216  
Email: [geokon@geokon.com](mailto:geokon@geokon.com)  
<http://www.geokon.com>

*Instruction Manual*  
**Model 1200**  
**A-4 Borehole Extensometer**

No part of this instruction manual may be reproduced, by any means, without the written consent of Geokon®.

The information contained herein is believed to be accurate and reliable. However, Geokon® assumes no responsibility for errors, omissions or misinterpretation. The information herein is subject to change without notification.

Copyright © 2002-2019 by Geokon®  
(Revision REV F 06/19/19)



## ***Warranty Statement***

Geokon warrants its products to be free of defects in materials and workmanship, under normal use and service for a period of 13 months from date of purchase. If the unit should malfunction, it must be returned to the factory for evaluation, freight prepaid. Upon examination by Geokon, if the unit is found to be defective, it will be repaired or replaced at no charge. However, the WARRANTY is VOID if the unit shows evidence of having been tampered with or shows evidence of being damaged as a result of excessive corrosion or current, heat, moisture or vibration, improper specification, misapplication, misuse or other operating conditions outside of Geokon's control. Components which wear or which are damaged by misuse are not warranted. This includes fuses and batteries.

Geokon manufactures scientific instruments whose misuse is potentially dangerous. The instruments are intended to be installed and used only by qualified personnel. There are no warranties except as stated herein. There are no other warranties, expressed or implied, including but not limited to the implied warranties of merchantability and of fitness for a particular purpose. Geokon is not responsible for any damages or losses caused to other equipment, whether direct, indirect, incidental, special or consequential which the purchaser may experience as a result of the installation or use of the product. The buyer's sole remedy for any breach of this agreement by Geokon or any breach of any warranty by Geokon shall not exceed the purchase price paid by the purchaser to Geokon for the unit or units, or equipment directly affected by such breach. Under no circumstances will Geokon reimburse the claimant for loss incurred in removing and/or reinstalling equipment.

Every precaution for accuracy has been taken in the preparation of manuals and/or software, however, Geokon neither assumes responsibility for any omissions or errors that may appear nor assumes liability for any damages or losses that result from the use of the products in accordance with the information contained in the manual or software.



# TABLE of CONTENTS

<b>1. INTRODUCTION .....</b>	<b>1</b>
<b>2. PRELIMINARY REQUIREMENTS .....</b>	<b>2</b>
2.1 BOREHOLE REQUIREMENTS .....	2
2.2 ANCHOR SPACING .....	2
2.3 INSTRUMENT HEAD PROTECTION .....	2
2.4 SWAGELOK TUBE FITTING INSTRUCTIONS .....	2
2.4.1 <i>Installation</i> .....	2
2.4.2 <i>Reassembly Instructions</i> .....	3
2.5 LIST OF INSTALLATION TOOLS REQUIRED .....	5
<b>3. ASSEMBLY AND INSTALLATION .....</b>	<b>6</b>
3.1 STANDARD SYSTEM WITH MANUAL READOUT .....	6
3.2 STANDARD SYSTEM WITH VIBRATING WIRE READOUT .....	8
<b>4. TAKING READINGS.....</b>	<b>11</b>
4.1 MANUAL READINGS .....	11
4.2 ELECTRONIC READOUT.....	11
4.3 GK-404 READOUT BOX.....	11
4.3.1 <i>Operating the GK-404</i> .....	11
4.4 GK-405 READOUT BOX.....	13
4.4.1 <i>Connecting Sensors with 10-pin Bulkhead Connectors Attached</i> .....	13
4.4.2 <i>Connecting Sensors with Bare Leads</i> .....	13
4.4.3 <i>Operating the GK-405</i> .....	13
4.5 GK-403 READOUT BOX (OBSOLETE MODEL).....	14
4.5.1 <i>Connecting Sensors with 10-pin Bulkhead Connectors Attached</i> .....	14
4.5.2 <i>Connecting Sensors with Bare Leads</i> .....	14
4.5.3 <i>Operating the GK-403</i> .....	14
<b>5. DATA ANALYSIS.....</b>	<b>15</b>
5.1 AN EXAMPLE OF MPBX DATA REDUCTION FOR A SITUATION WHERE THE DEEP ANCHOR IS IN STABLE GROUND.....	15
<b>6. TROUBLESHOOTING.....</b>	<b>18</b>
6.1 DIAL INDICATORS.....	18
6.2 VIBRATING WIRE TRANSDUCERS .....	18
<b>APPENDIX A. WIRING CHARTS FOR VIBRATING WIRE TRANSDUCERS.....</b>	<b>19</b>
A.1 SINGLE TRANSDUCER WIRING CHART .....	19
A.2 TWO TRANSDUCER WIRING CHART .....	19
A.3 THREE TRANSDUCERS WIRING CHART .....	19
A.4 FOUR TRANSDUCERS WIRING CHART .....	20
A.5 FIVE TRANSDUCERS WIRING CHART .....	20
A.6 SIX TRANSDUCERS WIRING CHART .....	21
A.7 SEVEN TRANSDUCERS WIRING CHART .....	21
A.8 EIGHT TRANSDUCERS WIRING CHART .....	22
<b>APPENDIX B. SPECIFICATIONS .....</b>	<b>23</b>
B.1 MODEL 1200 SPECIFICATIONS .....	23
B.2 ROD SPECIFICATIONS .....	23
B.3 MODEL 4450 VIBRATING WIRE TRANSDUCER SPECIFICATIONS.....	23
<b>APPENDIX C. THERMISTOR TEMPERATURE DERIVATION.....</b>	<b>24</b>

## FIGURES

FIGURE 1 - TUBE INSERTION .....	2
FIGURE 2 - MAKE A MARK AT SIX O’CLOCK .....	3
FIGURE 3 - TIGHTEN ONE AND ONE-QUARTER TURNS .....	3
FIGURE 4 - MARKS FOR REASSEMBLY .....	4
FIGURE 5 - FERRULES SEATED AGAINST FITTING BODY .....	4
FIGURE 6 - TIGHTEN NUT SLIGHTLY .....	4
FIGURE 7 – STANDARD SYSTEM WITH MANUAL READOUT .....	6
FIGURE 8 – STANDARD SYSTEM WITH VIBRATING WIRE READOUT .....	8
FIGURE 9 - LEMO CONNECTOR TO GK-404 .....	12
FIGURE 10 - LIVE READINGS – RAW READINGS .....	13
FIGURE 11 - MOVEMENT OF THE HEAD AND ANCHORS RELATIVE TO ANCHOR 3 IN STABLE GROUND .....	17
FIGURE 12 - MOVEMENTS OCCURRING IN EACH INTER-ANCHOR ZONE .....	17

## TABLES

TABLE 1 - RAW DATA .....	15
TABLE 2 - RELATIVE MOVEMENT BETWEEN THE INSTRUMENT HEAD AND EACH ANCHOR .....	16
TABLE 3 - MOVEMENT OF THE INSTRUMENT HEAD AND ANCHORS RELATIVE TO ANCHOR 3 IN STABLE GROUND .....	16
TABLE 4 - WIRING FOR ONE TRANSDUCER .....	19
TABLE 5 - WIRING FOR TWO TRANSDUCERS .....	19
TABLE 6 - WIRING FOR THREE TRANSDUCERS .....	19
TABLE 7 - WIRING FOR FOUR TRANSDUCERS .....	20
TABLE 8 - WIRING FOR FIVE TRANSDUCERS .....	20
TABLE 9 - WIRING FOR SIX TRANSDUCERS .....	21
TABLE 10 - WIRING FOR SEVEN TRANSDUCERS .....	21
TABLE 11 - WIRING FOR EIGHT TRANSDUCERS .....	22
TABLE 12 - A-4 EXTENSOMETER SPECIFICATIONS .....	23
TABLE 13 - ROD SPECIFICATIONS .....	23
TABLE 14 - MODEL 4450 DISPLACEMENT TRANSDUCER SPECIFICATIONS .....	23
TABLE 15 - THERMISTOR RESISTANCE VERSUS TEMPERATURE .....	24

## TABLES

EQUATION 1 - RESISTANCE TO TEMPERATURE .....	24
--	----

## **1. INTRODUCTION**

The Model A-4 Multiple Position Borehole Extensometer, (MPBX), is designed for rapid installation in upwardly directed boreholes, in hard rock, that are smooth and uniform in diameter. It is made up of three to four basic components:

### 1) Snap-Ring Borehole anchors:

Snap-ring type borehole anchors are made from Delrin or stainless steel cylindrical blocks on which two retaining rings are held, in their retracted position, by a pull-pin. The anchors are easily installed by pushing them to their correct positions in the borehole and then pulling out the pull-pins allowing the retaining rings to snap out against the borehole wall. Usually the number of anchors lies between one and six.

### 2) Connecting rods:

Standard connecting rods are made from 1/4-inch stainless steel. The sections of stainless steel rod are flush coupled to form a continuous string. Fiberglass rods may also be used, but their higher modulus may lead to lower precision in applications where high resolution, ( $>0.1$  mm), is required. Graphite rods, which have a very low thermal coefficient, are available for high temperature applications and for applications where thermal effects on the rods must be minimized.

### 3) Extensometer head assembly:

Various styles of head assemblies are available. The head is usually designed for recessing into the borehole. Provision may be made for manual or electronic readout or for both. Manual readout is by a 50 mm range dial indicator.

### 4) Electronic displacement transducers (optional):

The standard transducer is the model 4450 vibrating wire displacement transducer with ranges of 25, 50, or 100 mm. Linear potentiometers are also available.

## **2. PRELIMINARY REQUIREMENTS**

### **2.1 Borehole Requirements**

The Model A-4 is designed to fit inside boreholes with closely controlled diameters ( $\pm 1-2$  mm). This is because the snap-ring anchors have a very limited range of movement. Diamond-drill holes are ideal. Percussively drilled boreholes should be drilled carefully to avoid changes in diameter and excessive rifling.

Borehole diameters can be checked using a GO/NO GO Gauge. If the NO GO gauge fits into the borehole, oversize rings or a larger diameter anchor must be used. If the GO gauge (snap ring anchor) fits into the borehole, to the predetermined depth, then installation may proceed.

### **2.2 Anchor Spacing**

Anchor spacing is sometimes dictated by geologic features and by the size and geometry of the rock mass being monitored. Drill cores can be inspected to reveal zones and planes of weakness, which would suggest appropriate anchor locations. At least one anchor, usually the deepest anchor, should be installed in stable ground so that it can serve as a nonmoving point of reference for the rest of the anchors. For extensometers installed in tunnels the deepest anchor should be installed at least one tunnel diameter, and preferably nearer two tunnel diameters, away from the tunnel wall.

### **2.3 Instrument Head Protection**

The instrument head should be protected from damage. This may require recessing the instrument head inside the borehole to avoid blasting damage or, in exposed locations the construction of a protective enclosure, to ward against falling objects, moving equipment and vandalism.

### **2.4 Swagelok Tube Fitting Instructions**

These instructions apply to one inch (25 mm) and smaller fittings.

#### **2.4.1 Installation**

- 1) Fully insert the tube into the fitting until it bumps against the shoulder.

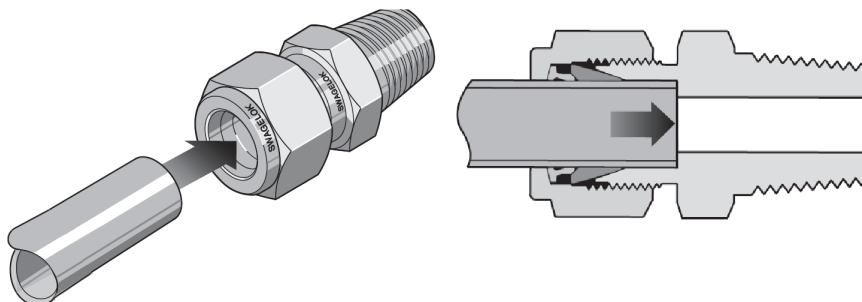

**Figure 1 - Tube Insertion**



- 2) Rotate the nut until it is finger-tight. (For high-pressure applications as well as high-safety-factor systems, further tighten the nut until the tube will not turn by hand or move axially in the fitting.)
- 3) Mark the nut at the six o'clock position.

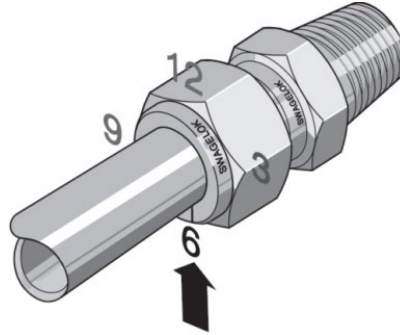

Figure 2 - Make a Mark at Six O'clock

- 4) While holding the fitting body steady, tighten the nut one and one-quarter turns until the mark is at the nine o'clock position. (Note: For 1/16", 1/8", 3/16" and 2, 3, and 4 mm fittings, tighten the nut three-quarters of a turn until the mark is at the three o'clock position.)

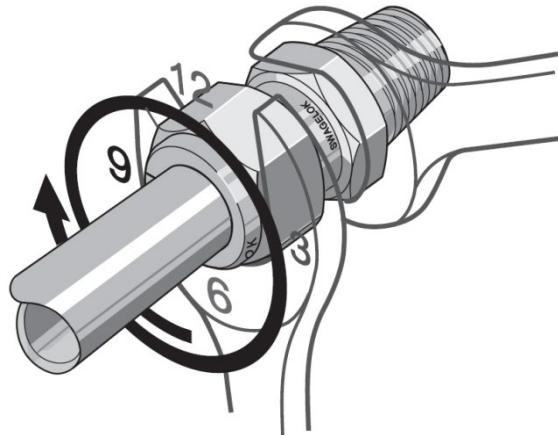

Figure 3 - Tighten One and One-Quarter Turns

#### 2.4.2 Reassembly Instructions

Swagelok tube fittings may be disassembled and reassembled many times.

**Warning:** Always depressurize the system before disassembling a Swagelok tube fitting.

- 1) Prior to disassembly, mark the tube at the back of the nut, then make a line along the nut and fitting body flats. *These marks will be used during reassembly to ensure the nut is returned to its current position.*

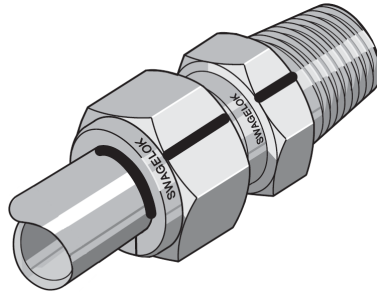

**Figure 4 - Marks for Reassembly**

- 2) Disassemble the fitting.
- 3) Inspect the ferrules for damage and replace if necessary. **If the ferrules are replaced the connector should be treated as a new assembly. Refer to the section above for installation instructions.**
- 4) Reassemble the fitting by inserting the tube with preswaged ferrules into the fitting until the front ferrule seats against the fitting body.

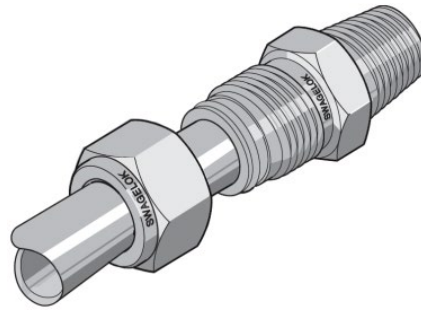

**Figure 5 - Ferrules Seated Against Fitting Body**

- 5) While holding the fitting body steady, rotate the nut with a wrench to the previous position as indicated by the marks on the tube and the connector. At this point, there will be a significant increase in resistance.
- 6) Tighten the nut slightly.

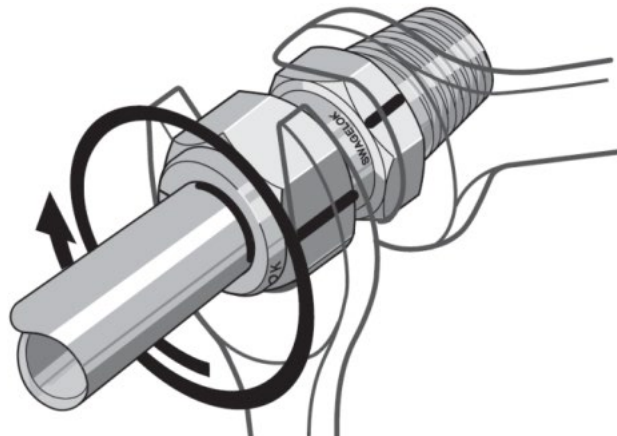

**Figure 6 - Tighten Nut Slightly**

## 2.5 List of Installation Tools Required

Installation Tool kits may be purchased as an accessory. They may include the following:

1. Two pair of Vise Grips
2. Adjustable wrenches
3. Screw Drivers
4. Allen Wrenches
5. Hacksaw
6. Files
7. Tape measure
8. Marking Pens
9. Loctite adhesive
10. Sharp Knife
11. Tape (Filament)
12. Tape Masking
13. Tape (Duct)
14. Two Hose Clamps (Sized to match anchor size)
15. Cable for pulling pull-pins
16. Setting Rods (For anchors larger than 60 mm [2 1/2 in.] in diameter)
17. Roof Level Instrument Head Positioning tool (Supplied)
18. Extension Rods (Supplied)

### **3. ASSEMBLY AND INSTALLATION**

There are many variations in the design of specific systems manufactured for specific situations. The following instructions are somewhat generic in nature and mainly provide an explanation for why the various procedures are necessary. The reader should be aware that special instructions are included with each system supplied, and these should be the ones used in guiding the installation procedure.

#### **3.1 Standard System with Manual Readout**

A typical system is shown in Figure 7.

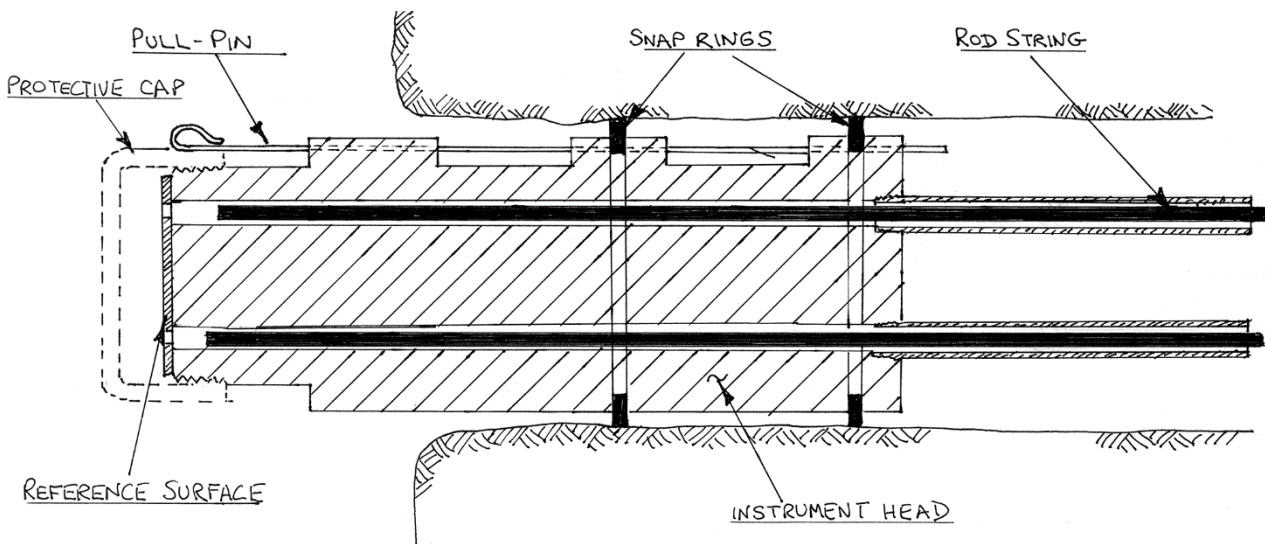

**Figure 7 – Standard System with Manual Readout**

- 1) Once the anchor depths have been determined, the correct lengths of 1/4 inch rods can be selected, and then screwed together using a pair of vise-grips. Use Loctite or similar adhesive on the threads. Rods are supplied, bundled according to the anchor depths specified, or, bundled in different lengths to be used with a rod table, which specifies how many of each length should be used to make up each rod string. The readout end of the rod string uses a stainless steel rod tip that is marked in red. This special rod tip has a setscrew that has been machined flat.
- 2) Select the correct anchor to be attached to the rod string. Anchors are numbered: number one anchor is usually the shallowest anchor and the largest number is on the deepest anchor. The anchor end of the rod string is pushed, first through the anchor, and then out through the Swagelok fitting on the far side of the anchor. Tighten the Swagelok connector onto the rod string at a point that gives the correct anchor depth. (See Section 2.4 for Swagelok instructions.) Excess rod length can be removed by using a Hacksaw on the rod protruding beyond the anchor.
- 3) It is important that the readout ends of all the rod strings terminate at the same correct depth inside the mouth of the borehole. (The correct depth is that which will place the ends of the rods at the desired distance away from the Reference Surface inside the instrument Head. This distance will depend on the magnitude and direction of the movement anticipated. Normally, where anticipated movements are extensions, the distance is around 10 mm).

- 4) The position of the reference surface must also be decided upon, i.e. whether it is to be recessed inside the borehole, flush with the mouth of the borehole or protruding to some degree). This is accomplished by screwing extension rods onto the ends of rod strings. The threads are not tightened, and no Loctite is used. Each extension rod is marked with permanent marker at a point which will be opposite of the roof level when the rod string is inserted to the proper depth. In addition, each extension rod should be marked with the anchor number.
- 5) Mark the mouth of the borehole with an orientation indicator. This mark will be the orientation point for all anchors and coincides with the orientation of the deepest rod string marked on each of the anchors and in the head assembly. The purpose of this is to prevent the rod strings from becoming tangled inside the borehole.
- 6) Mount the deepest anchor onto the setting rod and connect the pulling cable to the pull-pin. Push the assembly into the borehole, adding additional setting rods as required (and maintaining orientation) until the mark on the extension rod coincides with the plane of the rock face.
- 7) When the anchor is at the correct depth (i.e. the mark on the extension rod is opposite the roof level), hold the position of the setting rods, then pull the pulling cable to release the pull-out pin and set the anchor. Remove the setting rods and pull pin cord for use on the next anchor.
- 8) Repeat steps one through six for successive anchors, feeding subsequent connecting rods through the appropriately numbered holes in the anchors while maintaining orientation. When all the anchors are set, the quantity of extension rods sticking out of the hole will equal the amount of the position anchors installed. Be sure that all the marks on the extension rods end up at the same position relative to the mouth of the borehole rock face, and that the numbers on the extension rods are in their proper sequence corresponding with the sequence of numbers marked on the instrument head.
- 9) Connect the roof-level positioning tool to the threaded hole in the center of the stainless steel Reference Surface. Connect the pulling cable to the Head Anchor pull-pin. Slide the matching numbered extension rods into the same numbered holes in the roof level anchor. Push the instrument head into the borehole and stop at the predetermined elevation. Hold the position of the roof level positioning tool and pull the pulling cable to release the pull out pin and set the anchor
- 10) Remove the extension rods and take initial readings with a Dial Indicator.
- 11) Thread the protective cap onto the Instrument Head.

### 3.2 Standard System with Vibrating Wire Readout

A typical system is shown in Figure 8.

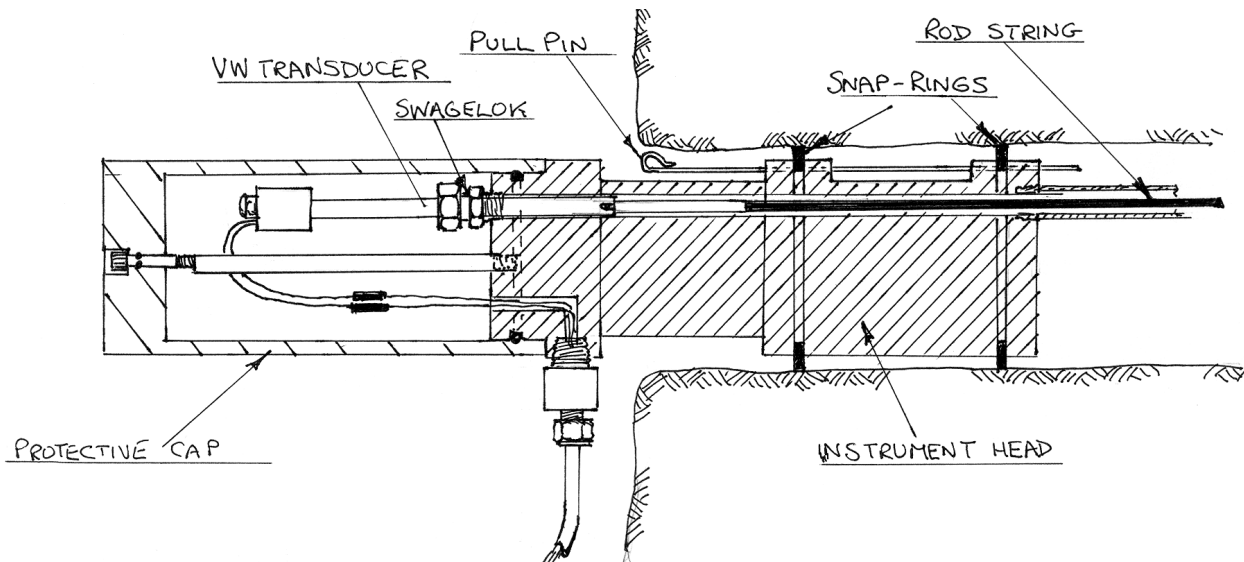

Figure 8 – Standard System with Vibrating Wire Readout

- 1) Once the anchor depths have been determined, the correct lengths of 1/4 inch rods can be selected, and then screwed together using a pair of vise-grips. Use Loctite or similar adhesive on the threads. (Allowance must be made for the length of the transducers in use and their position inside the mouth of the borehole). Rods are supplied, bundled according to the anchor depths specified, or, bundled in different lengths to be used with a rod table, which specifies how many of each length should be used to make up each rod string. The readout end of the rod string uses a stainless steel rod tip that is marked in red. This special rod tip has a setscrew that has been machined flat.
- 2) Select the correct anchor to be attached to the rod string. Anchors are numbered: number one anchor is usually the shallowest anchor and the largest number is on the deepest anchor. The anchor end of the rod string is pushed, first through the anchor, and then out through the Swagelok fitting on the far side of the anchor. Tighten the Swagelok connector onto the rod string at a point that gives the correct anchor depth. (See Section 2.4 for Swagelok instructions.) Excess rod length can be removed by using a Hacksaw on the rod protruding beyond the anchor.
- 3) It is important that the readout ends of all the rod strings terminate at the same correct depth inside the mouth of the borehole. (The correct depth is that which will place the ends of the rods at the desired depth inside the instrument Head. This distance will depend on the length of the VW Transducers and the depth to which they are to be recessed inside the borehole. This distance must be determined in advance of installation). This is accomplished by screwing extension rods onto the ends of rod strings. The threads are not tightened, and no Loctite is used. Each extension rod has a taper on its outward end and is marked with permanent marker at a point which will be opposite of the roof level when the rod string is inserted to the proper depth. In addition, each extension rod should be marked with the anchor number.

- 4) Mark the mouth of the borehole with an orientation indicator. This mark will be the orientation point for all anchors and coincides with the orientation of the deepest rod string marked on each of the anchors and in the head assembly. The purpose of this is to prevent the rod strings from becoming tangled inside the borehole.
- 5) Mount the deepest anchor onto the setting rod and connect the pulling cable to the pull-pin. Push the assembly into the borehole, adding additional setting rods as required (and maintaining orientation) until the mark on the extension rod coincides with the plane of the rock face.
- 6) When the anchor is at the correct depth, (i.e. the mark on the extension rod is opposite the roof level), hold the position of the setting rods, and pull the pulling cable to release the pull-out pin and set the anchor. Remove the setting rods and pull pin cord for use on the next anchor.
- 7) Repeat steps one through six for successive anchors, feeding subsequent connecting rods through the appropriately numbered holes in the anchors while maintaining orientation. When all the anchors are set, the quantity of extension rods sticking out of the hole will equal the amount of the position anchors installed. Be sure that all the marks on the extension rods end up at the same position, relative to the mouth of the borehole rock face, and that the numbers on the extension rods are in their proper sequence corresponding with the sequence of numbers marked on the instrument head.
- 8) Remove the Housing Cap from the Transducer Housing by loosening the cap screw holding the Cap to the Center Post. The Cap screw has an O-ring on it.
- 9) Attach the pulling cable to the pull-pin on the transducer housing. Connect the roof-level positioning tool to the Center Post.
- 10) Slide each of the numbered extension rods into the matching numbered Guide Tube on the base of the Transducer Housing. Push the instrument head into the borehole and stop at the predetermined depth. Hold the position of the roof-level positioning tool and pull the pulling cable to release the pull-out pin and set the anchor.
- 11) Remove all the extension rods and the roof-level positioning tool.
- 12) Select a transducer and record a) the serial number b) the extensometer that it is being used in and c) the specific anchor position. Remove the zip tie around the transducer shaft. (This zip tie prevents damage to the transducer during shipment.)  
**Note: Do not extend the transducer by pulling on the shaft beyond its range. Do not twist the shaft inside the rest of the body beyond one-half turn.**
- 13) Loosen, but do not remove, the Swagelok nut in the #1 position.
- 14) Push the transducer through the fitting until it engages the end of the connecting rod. Rotate the sensor clockwise until it is tight on the connecting rod (about 16 turns). **Be sure the pin in the transducer shaft is in the notch on the transducer tube before tightening or the transducer may be broken.**

- 15) Connect the GK-404 or GK-405 Readout Box to the #1 gauge leads and turn on the box (Position B). Note: The range of the sensor is approximately 5,000 digits, starting at 2,000 and ending at 7,000 (plus some overrange capability.) To set the sensor at midrange, the reading should be about 4,500. For 1/3 compression, 2/3 extension, set at approximately 3,600. For 1/3 extension and 2/3 compression, set at approx. 5,300. Repeat for all the gauges. Note: The reading may be unsteady with the shaft pin inside the tube notch and the transducer fully closed.
- 16) While observing the readout box display, gently pull on the sensor until the desired reading is obtained. Then, with the Tube wrench supplied, tighten the Swagelok according to the instructions in Section 2.4.
- 17) Repeat steps 12 through 16 for the remaining transducers.
- 18) The next step is to attach the lead wires from the transducers to the cable wires in the cap using a crimping tool. Cut the sensor wires to an acceptable length and then strip back the insulation approximately 3/8" (8 mm). Push the stripped wire into the crimp and actuate the crimper. Test each lead after crimping by pulling on it. If any are loose, cut off the crimp and remake the splice.
- 19) Check the gauges with the VW readout box by connecting the 10-pin connector on the cable from the head assembly.
- 20) Slide the Housing Cap over the O-ring seal on the Transducer Housing and secure in place to the Center Post using the 1/4-20 cap screw with the O-ring seal. Tighten the cable gland nut to secure the cable in the cap.



## **4. TAKING READINGS**

The most important reading is the first reading: it is the base reading to which all subsequent readings will be compared. Verify that the readings are correct. If possible, install the MPBX well ahead of the time that movements are expected so that the MPBX has time to stabilize. (Most installations are subject to a “bedding in” process during which slight movements can occur. These movements generally cease after two or three days). Often the best results can be obtained by using as the base line readings the readings taken on the third day. This, of course may not be possible if the ground is already moving.

### **4.1 Manual Readings**

Manual readings are best taken using a dial indicator, although, depth micrometers have also been used. To take manual readings simply poke the stem of the indicator through the holes in the Cap on the MPBX Head assembly until the tip bears against the underlying Swagelok Cap. With the collar of the dial indicator held flush against the MPBX Cap or the Reference Surface take a reading on the indicator.

### **4.2 Electronic Readout**

Readout frequency should be suitable to the purpose for which the readings are being made. All readings should be compared with previous readings as soon as they are taken. In this way, sudden changes of readings can be instantly checked to see if they are real or perhaps a reading error. If the changes are real, the observer is alerted to the possibility of serious ground movements, or to possible instrument damage, and can look for further evidence of either.

### **4.3 GK-404 Readout Box**

The Model GK-404 Vibrating Wire Readout is a portable, low-power, handheld unit that can run continuously for more than 20 hours on two AA batteries. It is designed for the readout of all Geokon vibrating wire gauges and transducers; and is capable of displaying the reading in either digits, frequency (Hz), period ( $\mu\text{s}$ ), or microstrain ( $\mu\epsilon$ ). The GK-404 also displays the temperature of the transducer (embedded thermistor) with a resolution of 0.1 °C.

#### **4.3.1 Operating the GK-404**

Before use, attach the flying leads to the GK-404 by aligning the red circle on the silver “Lemo” connector of the flying leads with the red line on the top of the GK-404, as shown as Figure 9 below. Insert the Lemo connector into the GK-404 until it locks into place.



**Figure 9 - Lemo Connector to GK-404**

Connect each of the clips on the leads to the matching colors of the sensor conductors, with blue representing the shield (bare).

To turn the GK-404 on, press the “ON/OFF” button on the front panel of the unit. The initial startup screen will display:

Geokon Inc.  
GK-404 verX.XX

After approximately one second, the GK-404 will start taking readings and display them based on the settings of the POS and MODE buttons.

The unit display (from left to right) is as follows:

- The current Position: Set by the **POS** button, displayed as a letter A through F.
- The current Reading: Set by the **MODE** button, displayed as a numeric value followed by the unit of measure.
- Temperature reading of the attached gauge in degrees Celsius.

Use the **POS** button to select position **B** and the **MODE** button to select **Dg** (digits). (Other functions can be selected as described in the GK-404 Manual.)

The GK-404 will continue to take measurements and display readings until the unit is turned off, either manually, or if enabled, by the Auto-Off timer. If no reading displays or the reading is unstable, consult Section 6 for troubleshooting suggestions.

For further information, please see the GK-404 manual.

## 4.4 GK-405 Readout Box

The GK-405 Vibrating Wire Readout is made up of two components: The Readout Unit, consisting of a Windows Mobile handheld PC running the GK-405 Vibrating Wire Readout Application; and the GK-405 Remote Module, which is housed in a weatherproof enclosure and connects via a cable to the vibrating wire gauge to be measured. The two components communicate wirelessly. The Readout Unit can operate from the cradle of the Remote Module, or, if more convenient, can be removed and operated up to 20 meters from the Remote Module.

### 4.4.1 Connecting Sensors with 10-pin Bulkhead Connectors Attached

Align the grooves on the sensor connector (male), with the appropriate connector on the readout (female connector labeled sensor or load cell). Push the connector into place, and then twist the outer ring of the male connector until it locks into place.

### 4.4.2 Connecting Sensors with Bare Leads

Attach the GK-403-2 flying leads to the bare leads of a Geokon vibrating wire sensor by connecting each of the clips on the leads to the matching colors of the sensor conductors, with blue representing the shield (bare).

### 4.4.3 Operating the GK-405

Press the button labeled “POWER ON”. A blue light will begin blinking, signifying that the Remote Module is waiting to connect to the handheld unit. Launch the GK-405 VWRA program by tapping on “Start” from the handheld PC’s main window, then “Programs” then the GK-405 VWRA icon. After a few seconds, the blue light on the Remote Module should stop flashing and remain lit. The Live Readings Window will be displayed on the handheld PC. Choose display mode “B”. Figure 10 shows a typical vibrating wire output in digits and thermistor output in degrees Celsius. If no reading displays or the reading is unstable, see Section 6 for troubleshooting suggestions. For further information, consult the GK-405 Instruction Manual.

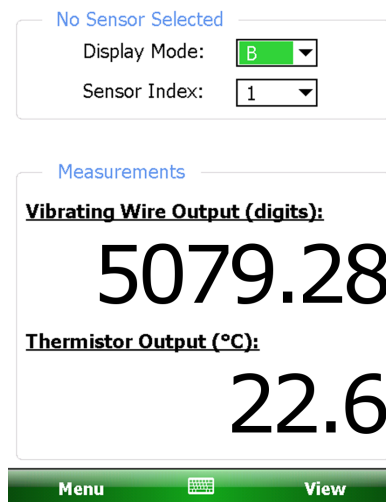

Figure 10 - Live Readings – Raw Readings

## **4.5 GK-403 Readout Box (Obsolete Model)**

The GK-403 can store gauge readings and apply calibration factors to convert readings to engineering units. The following instructions explain taking gauge measurements using Mode “B”. Consult the GK-403 Instruction Manual for additional information.

### **4.5.1 Connecting Sensors with 10-pin Bulkhead Connectors Attached**

Align the grooves on the sensor connector (male), with the appropriate connector on the readout (female connector labeled sensor or load cell). Push the connector into place, and then twist the outer ring of the male connector until it locks into place.

### **4.5.2 Connecting Sensors with Bare Leads**

Attach the GK-403-2 flying leads to the bare leads of a Geokon vibrating wire sensor by connecting each of the clips on the leads to the matching colors of the sensor conductors, with blue representing the shield (bare).

### **4.5.3 Operating the GK-403**

- 1) Turn the display selector to position “B”.
- 2) Turn the unit on.
- 3) The readout will display the vibrating wire output in digits. The last digit may change one or two digits while reading.
- 4) The thermistor reading will be displayed above the gauge reading in degrees centigrade.
- 5) Press the “Store” button to record the value displayed.

If the no reading displays or the reading is unstable, see Section 6 for troubleshooting suggestions.

The unit will automatically turn off after approximately two minutes to conserve power.

## **5. DATA ANALYSIS**

Raw data can be treated in several ways to reveal zones or planes of weakness in which movement is occurring. All raw data must be converted into time plots as soon as possible. Failure to plot the data in a timely manner can negate the purposes of the monitoring program. Inspection of the plots will show whether movements are steady, are accelerating, or have stopped. They may suggest the need for remedial measures and will be useful in monitoring their efficacy.

### **5.1 An Example of MPBX Data Reduction for a Situation where the Deep Anchor is in Stable Ground**

Table 1 shows a series of entries into a field book. In this example, Anchor 3 is located in stable ground.

Date	Anchor 3 (Depth 20 m) millimeters	Anchor 2 (Depth 10 m) millimeters	Anchor 1 (Depth 3 m) millimeters	Remarks
12/01/00	38.10	25.19	34.75	Initial Reading ( $R_0$ )
12/02/00	38.91	26.01	35.51	
12/03/00	39.01	26.11	35.61	
12/05/00	39.12	26.16	35.61	
12/06/00	39.14	26.16	35.61	
12/08/00	40.18	27.13	36.58	Blasting in the Area
12/09/00	40.13	27.18	36.63	
12/10/00	40.26	27.31	36.65	
12/11/00	40.64	27.61	36.65	
12/15/00	43.82	28.58	36.83	Heavy Rain
12/16/00	43.87	28.58	36.83	
12/18/00	43.94	28.63	36.88	
12/20/00	43.99	28.65	36.88	

**Table 1 - Raw Data**

The first task is to calculate the measured displacements between the head and each anchor. This can easily be done for each anchor, by subtracting the initial reading,  $R_0$  from each of the subsequent readings. This creates the table of figures as shown in Table 2.

Date	Anchor 3 (Depth 20 m) millimeters	Anchor 2 (Depth 10 m) millimeters	Anchor 1 (Depth 3 m) millimeters	Remarks
12/01/00	0.00	0.00	0.00	Installed
12/02/00	0.81	0.82	0.76	
12/03/00	0.91	0.92	0.86	
12/05/00	1.02	0.97	0.86	
12/06/00	1.04	0.97	0.86	
12/08/00	2.08	1.94	1.83	Blasting in the Area
12/09/00	2.03	1.99	1.88	
12/10/00	2.16	2.12	1.90	
12/11/00	2.54	2.42	1.90	
12/15/00	5.72	3.39	2.08	Heavy Rain
12/16/00	5.75	3.39	2.08	
12/18/00	5.84	3.44	2.13	
12/20/00	5.89	3.46	2.13	

**Table 2 - Relative Movement between the Instrument Head and Each Anchor**

However, in the example chosen, it is the deepest anchor that is stable, not the Instrument Head, so that the movement of each of the anchors should be calculated relative to Anchor 3 and not to the head of the MPBX. Immediately it will be realized that the apparent movement of Anchor 3 is actually the absolute movement of the instrument head relative to stable ground.

When the Instrument head is located in stable ground, such as would be the case for a MPBX head located at street level in a borehole drilled downwards to terminate slightly above a tunnel being excavated below, then the measured movements on each anchor are taken directly from the readings on each anchor. The analysis of the data would then proceed as before without the need for the steps described below.

Date	Anchor 2 (Depth 10 m) millimeters	Anchor 1 (Depth 3 m) millimeters	Instrument Head millimeters	Remarks
12/01/00	0.00	0.00	0.00	Installed
12/02/00	0.01	0.05	0.81	
12/03/00	0.01	0.05	0.91	
12/05/00	0.05	0.16	1.02	
12/06/00	0.07	0.18	1.04	
12/08/00	0.14	0.25	2.08	Blasting in the Area
12/09/00	0.04	0.15	2.03	
12/10/00	0.04	0.26	2.16	
12/11/00	0.12	0.64	2.54	
12/15/00	2.33	3.64	5.72	Heavy Rain
12/16/00	2.36	3.67	5.75	
12/18/00	2.40	3.71	5.84	
12/20/00	2.43	3.76	5.89	

**Table 3 - Movement of the Instrument Head and Anchors Relative to Anchor 3 in Stable Ground**

The data shown in Table 3 could be plotted and shown in a graph like the one shown in Figure 11.

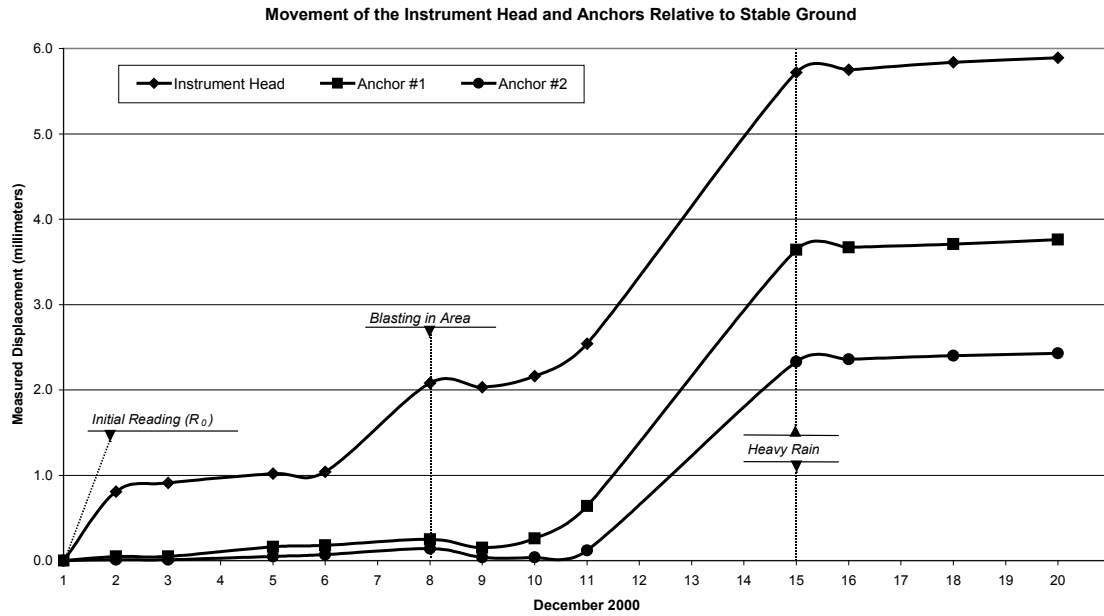

Figure 11 - Movement of the Head and Anchors Relative to Anchor 3 in Stable Ground

Inspection of the plot shows that initial movement occurred in the zone closest to the surface during the first three days and again on day eight following blasting in the area. On day 15, following a heavy rainfall, deep-seated movements occurred in the zone between Anchors 2 and 3 as well as in the shallower zones. Movements occurring in any inter-anchor zone can be inferred from the spacing between the individual plots of Figure 11, or they can be plotted separately as shown in Figure 12.

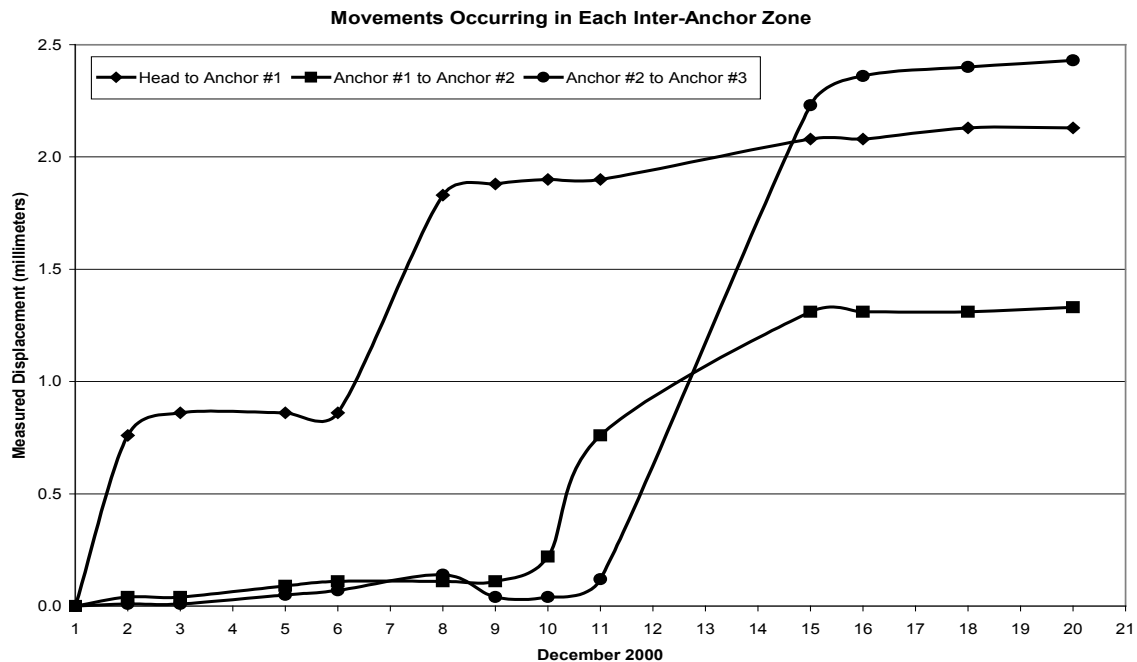

Figure 12 - Movements Occurring in Each Inter-Anchor Zone

## **6. TROUBLESHOOTING**

The multiple anchor design tends to show confirming changes of readings on several rods from movements that affect more than one anchor. Bad readings on any intermediate anchor will tend to stand out as incompatible with the movements of the surrounding anchors. Nevertheless, it is possible that cracks in one zone may open, while those in an adjacent zone might close.

### **6.1 Dial Indicators**

Dial Indicators are delicate instruments and should always be kept clean and dry. It is advisable to have a Standard, which can be used to check that the dial gauge always gives the same reading when checked against this Standard. The Standard might be a block of steel in which a hole has been bored.

### **6.2 Vibrating Wire Transducers**

#### ***Symptom: Displacement Transducer Readings are Unstable***

- ✓ Is the readout box position set correctly? If using a datalogger to record readings automatically, are the swept frequency excitation settings correct? Try reading the displacement transducer on a different readout position. For instance, channel A of the GK-404 and GK-405 might be able to read the transducer.
- ✓ Is there a source of electrical noise nearby? Most probable sources of electrical noise are motors, generators, transformers, arc welders, and antennas. Make sure the shield drain wire is connected to ground whether using a portable readout or datalogger. If using the GK-403, GK-404, or GK-405, connect the clip with the blue boot to the shield drain wire. (Green for the GK-401.)
- ✓ Does the readout work with another transducer? If not, the readout may have a low battery or be malfunctioning. Consult the appropriate readout manual for charging or troubleshooting directions.
- ✓ Has the transducer gone outside its range? If so, the transducer can be reset using the installation instructions in Section 3.2.

#### ***Symptom: Transducer Fails to Read***

- ✓ Is the cable cut or crushed? This can be checked with an ohmmeter. Nominal resistance between the two gauge leads (usually red and black leads) is  $180\Omega$ ,  $\pm 10\Omega$ . Remember to add cable resistance when checking (22 AWG stranded copper leads are approximately  $14.7\Omega/1000'$  or  $48.5\Omega/\text{km}$ , multiply by two for both directions). If the resistance reads infinite or very high (megohms), a cut wire must be suspected. If the resistance reads very low ( $<100\Omega$ ), a short in the cable is likely.
- ✓ Does the readout or datalogger work with another transducer? If not, the readout or datalogger may be malfunctioning. Consult the readout or datalogger manual for further direction.



## **APPENDIX A. WIRING CHARTS FOR VIBRATING WIRE TRANSDUCERS**

### **A.1 Single Transducer Wiring Chart**

<b>Internal Wiring</b>	<b>Geokon Cable #02-205V6 (Blue)</b>	<b>Function / Description</b>
Red	Red	Gauge 1+
Black	Black	Gauge 1-
Red	White	Thermistor
Black	Green	Thermistor
N/C	Shield (1)	N/A

**Table 4 - Wiring for One Transducer**

### **A.2 Two Transducer Wiring Chart**

<b>Internal Wiring</b>	<b>Geokon Cable #04-375V9</b>	<b>Function / Description</b>
Red	Red	Gauge 1+
Black	Black of Red	Gauge 1-
Red	White	Gauge 2+
Black	Black of White	Gauge 2-
Blue	Blue	Thermistor
Black of Blue	Black of Blue	Thermistor
N/C	Shields (4)	Ground

**Table 5 - Wiring for Two Transducers**

### **A.3 Three Transducers Wiring Chart**

<b>Internal Wiring</b>	<b>Geokon Cable #04-375V9 (Violet)</b>	<b>Function / Description</b>
Red	Red	Gauge 1+
Black	Black of Red	Gauge 1-
Red	White	Gauge 2+
Black	Black of White	Gauge 2-
Red	Green	Gauge 3+
Black	Black of Green	Gauge 3-
N/C	Blue	Thermistor
N/C	Black of Blue	Thermistor
N/C	Shields (5)	Ground

**Table 6 - Wiring for Three Transducers**

#### A.4 Four Transducers Wiring Chart

<b>Internal Wiring</b>	<b>Geokon Cable #05-375V12 (Tan)</b>	<b>Function / Description</b>
Red	Red	Gauge 1+
Black	Black of Red	Gauge 1-
Red	White	Gauge 2+
Black	Black of White	Gauge 2-
Red	Green	Gauge 3+
Black	Black of Green	Gauge 3-
Red	Blue	Gauge 4+
Black	Black of Blue	Gauge 4-
N/C	Yellow	Thermistor
N/C	Black of Yellow	Thermistor
N/C	Shields (6)	Ground

Table 7 - Wiring for Four Transducers

#### A.5 Five Transducers Wiring Chart

<b>Internal Wiring</b>	<b>Geokon Cable #06-500V7 (Orange)</b>	<b>Function / Description</b>
Red	Red	Gauge 1+
Black	Black of Red	Gauge 1-
Red	White	Gauge 2+
Black	Black of White	Gauge 2-
Red	Green	Gauge 3+
Black	Black of Green	Gauge 3-
Red	Blue	Gauge 4+
Black	Black of Blue	Gauge 4-
Red	Yellow	Gauge 5+
Black	Black of Yellow	Gauge 5-
Red	Brown	Thermistor
Black	Black of Brown	Thermistor
N/C	Shields (7)	Ground

Table 8 - Wiring for Five Transducers

### A.6 Six Transducers Wiring Chart

<b>Internal Wiring</b>	<b>Geokon Cable #012-625V5 (Brown CAB-507)</b>	<b>Function / Description</b>
Red	Red	Gauge 1+
Black	Black of Red	Gauge 1-
Red	White	Gauge 2+
Black	Black of White	Gauge 2-
Red	Green	Gauge 3+
Black	Black of Green	Gauge 3-
Red	Blue	Gauge 4+
Black	Black of Blue	Gauge 4-
Red	Yellow	Gauge 5+
Black	Black of Yellow	Gauge 5-
Red	Brown	Gauge 6+
Black	Black of Brown	Gauge 6-
White	White	Thermistor
Red of White	Red of White	Thermistor
N/C	Shields (8)	Ground

Table 9 - Wiring for Six Transducers

### A.7 Seven Transducers Wiring Chart

<b>Internal Wiring</b>	<b>Geokon Cable #012-625V5 (Brown)</b>	<b>Function / Description</b>
Red	Red	Gauge 1+
Black	Black of Red	Gauge 1-
Red	White	Gauge 2+
Black	Black of White	Gauge 2-
Red	Green	Gauge 3+
Black	Black of Green	Gauge 3-
Red	Blue	Gauge 4+
Black	Black of Blue	Gauge 4-
Red	Yellow	Gauge 5+
Black	Black of Yellow	Gauge 5-
Red	Brown	Gauge 6+
Black	Black of Brown	Gauge 6-
Red	Orange	Gauge 7+
Black	Black of Orange	Gauge 7-
N/C	White	Thermistor
N/C	Red of White	Thermistor
N/C	Shields (9)	Ground

Table 10 - Wiring for Seven Transducers

### A.8 Eight Transducers Wiring Chart

<b>Internal Wiring</b>	<b>Geokon Cable #012-625V5 (Brown)</b>	<b>Function / Description</b>
Red	Red	Gauge 1+
Black	Black of Red	Gauge 1-
Red	White	Gauge 2+
Black	Black of White	Gauge 2-
Red	Green	Gauge 3+
Black	Black of Green	Gauge 3-
Red	Blue	Gauge 4+
Black	Black of Blue	Gauge 4-
Red	Yellow	Gauge 5+
Black	Black of Yellow	Gauge 5-
Red	Brown	Gauge 6+
Black	Black of Brown	Gauge 6-
Red	Orange	Gauge 7+
Black	Black of Orange	Gauge 7-
Red	Red	Gauge 8+
Black	Green of Red	Gauge 8-
N/C	White	Thermistor
N/C	Red of White	Thermistor
N/C	Shields (10)	Ground

**Table 11 - Wiring for Eight Transducers**

## **APPENDIX B. SPECIFICATIONS**

### **B.1 Model 1200 Specifications**

<b>Standard Range</b>	Up to 300 mm nominal
<b>Least Reading</b>	0.025 mm
<b>Borehole Diameter<sup>1</sup></b>	38 mm to 76 mm
<b>Maximum Length</b>	50 m

Table 12 - A-4 Extensometer Specifications

Notes:

<sup>1</sup> Any borehole diameter up to 76 mm may be specified. Note that the size of the borehole required increases with the addition of more measuring points.

### **B.2 Rod Specifications**

<b>Material</b>	<b>Diameter</b>	<b>Weight per Meter</b>	<b>Young's Modulus</b>	<b>Temperature Coefficient</b>
<b>303 Stainless Steel</b>	6 mm	0.25 Kg/m	200 GPa	17.5 ppm/°C
<b>Fiberglass</b>	6 mm	0.06 Kg/m	20 GPa	3.0 ppm/°C
<b>Carbon Composite</b>	6 mm	0.05 Kg/m	130 GPa	<1.0 ppm/°C

Table 13 - Rod Specifications

### **B.3 Model 4450 Vibrating Wire Transducer Specifications**

<b>Standard Ranges<sup>1</sup> (mm)</b>	12.5, 25, 50, 100, 150, 200, 230, 300
<b>Resolution<sup>2</sup></b>	0.025% FSR
<b>Linearity</b>	0.25% FSR
<b>Thermal Zero Shift<sup>3</sup></b>	< 0.05% FSR/°C
<b>Stability</b>	< 0.2%/yr (under static conditions)
<b>Accuracy<sup>4</sup></b>	
<b>Overrange</b>	115%
<b>Temperature Range</b>	-20 to +80 °C
<b>Frequency Range</b>	1200 - 2800 Hz
<b>Coil Resistance</b>	180 Ω, ±10 Ω
<b>Cable Type<sup>5</sup></b>	Two twisted pair (four conductor) 22 AWG Foil shield, PVC jacket, nominal OD=6.3 mm (0.250")

Table 14 - Model 4450 Displacement Transducer Specifications

Notes:

<sup>1</sup> Other ranges available on request.

<sup>2</sup> Minimum; greater resolution possible depending on readout.

<sup>3</sup> Depends on application.

<sup>4</sup> Accuracy established under laboratory conditions.

<sup>5</sup> Polyurethane jacket cable available.

## **APPENDIX C. THERMISTOR TEMPERATURE DERIVATION**

Thermistor Type: YSI 44005, Dale #1C3001-B3, Alpha #13A3001-B3  
Resistance to Temperature Equation:

$$T = \frac{1}{A + B(\ln R) + C(\ln R)^3} - 273.15 \text{ } ^\circ\text{C}$$

**Equation 1 - Resistance to Temperature**

Where;

T = Temperature in °C.

LnR = Natural Log of Thermistor Resistance

A =  $1.4051 \times 10^{-3}$

B =  $2.369 \times 10^{-4}$

C =  $1.019 \times 10^{-7}$

Note: Coefficients calculated over the -50 to +150 °C. span.

Ohms	Temp	Ohms	Temp	Ohms	Temp	Ohms	Temp	Ohms	Temp
201.1K	-50	16.60K	-10	2417	+30	525.4	+70	153.2	+110
187.3K	-49	15.72K	-9	2317	31	507.8	71	149.0	111
174.5K	-48	14.90K	-8	2221	32	490.9	72	145.0	112
162.7K	-47	14.12K	-7	2130	33	474.7	73	141.1	113
151.7K	-46	13.39K	-6	2042	34	459.0	74	137.2	114
141.6K	-45	12.70K	-5	1959	35	444.0	75	133.6	115
132.2K	-44	12.05K	-4	1880	36	429.5	76	130.0	116
123.5K	-43	11.44K	-3	1805	37	415.6	77	126.5	117
115.4K	-42	10.86K	-2	1733	38	402.2	78	123.2	118
107.9K	-41	10.31K	-1	1664	39	389.3	79	119.9	119
101.0K	-40	9796	0	1598	40	376.9	80	116.8	120
94.48K	-39	9310	+1	1535	41	364.9	81	113.8	121
88.46K	-38	8851	2	1475	42	353.4	82	110.8	122
82.87K	-37	8417	3	1418	43	342.2	83	107.9	123
77.66K	-36	8006	4	1363	44	331.5	84	105.2	124
72.81K	-35	7618	5	1310	45	321.2	85	102.5	125
68.30K	-34	7252	6	1260	46	311.3	86	99.9	126
64.09K	-33	6905	7	1212	47	301.7	87	97.3	127
60.17K	-32	6576	8	1167	48	292.4	88	94.9	128
56.51K	-31	6265	9	1123	49	283.5	89	92.5	129
53.10K	-30	5971	10	1081	50	274.9	90	90.2	130
49.91K	-29	5692	11	1040	51	266.6	91	87.9	131
46.94K	-28	5427	12	1002	52	258.6	92	85.7	132
44.16K	-27	5177	13	965.0	53	250.9	93	83.6	133
41.56K	-26	4939	14	929.6	54	243.4	94	81.6	134
39.13K	-25	4714	15	895.8	55	236.2	95	79.6	135
36.86K	-24	4500	16	863.3	56	229.3	96	77.6	136
34.73K	-23	4297	17	832.2	57	222.6	97	75.8	137
32.74K	-22	4105	18	802.3	58	216.1	98	73.9	138
30.87K	-21	3922	19	773.7	59	209.8	99	72.2	139
29.13K	-20	3748	20	746.3	60	203.8	100	70.4	140
27.49K	-19	3583	21	719.9	61	197.9	101	68.8	141
25.95K	-18	3426	22	694.7	62	192.2	102	67.1	142
24.51K	-17	3277	23	670.4	63	186.8	103	65.5	143
23.16K	-16	3135	24	647.1	64	181.5	104	64.0	144
21.89K	-15	<b>3000</b>	<b>25</b>	624.7	65	176.4	105	62.5	145
20.70K	-14	2872	26	603.3	66	171.4	106	61.1	146
19.58K	-13	2750	27	582.6	67	166.7	107	59.6	147
18.52K	-12	2633	28	562.8	68	162.0	108	58.3	148
17.53K	-11	2523	29	543.7	69	157.6	109	56.8	149
								55.6	150

**Table 15 - Thermistor Resistance versus Temperature**